

Hand Grip Measure Device Post-Stroke Patients

Ria Ramadhani # Endang Dian Setioningsih, Torib Hamzah
Department of Electromedical Engineering Poltekkes Kemenkes, Surabaya
Jl. Pucang East Jajar No. 10, Surabaya, 60245, Indonesia
#Riaramadhani3@gmail.com , diancholik@gmail.com , trbhamzah@gmail.com

Abstract- Handgrip Dynamometer is a device used to view the strength of the hand muscles post-stroke patients. In this study Handgrip Dynamometer created to look at the hand grip strength in real time and find out the hand grip strength criteria, there are three indicators: the criteria of mild, moderate or strong. Handgrip dynamometer using the Arduino Uno control over the entire system and Load Cell as a sensor. Load Cell Output will be boosted by Analog Signal conditioner HX711 and then processed in the microcontroller, then will be displayed on the LCD. Base on weight measurement results obtained by the result of error by 0% By comparison to using weights, so we can be concluded that the device can be used according to its function.

Keywords- Keywords: Grip Strength, Arduino Uno, Load Cell

I. INTRODUCTION

Handgrip Dynamometer is a device used to measure muscle strength handheld. However, the device can only be used to measure the maximum force the hand grip [1], so it can not be used to display the grip style post-stroke patients in real time. If a stroke patient is paralyzed hands, feet and face on one side of the body, affects muscle contraction [2]. Reduced muscle contraction caused loose of blood supply to the brain and the brain behind the center, so as to inhibit the conduction pathway-main pathways between the brain and spinal cord, and in total led to the inability of sensorimotor abnormalities.

Understanding muscle is the tissue that exist in the human body, in the form of active locomotor move the bones, causing an organism or individual are potentially move. Muscles work by contracting and relaxing. Muscle function in humans, namely: run and carry out work for example walking, lifting, and holds; move the heart; blood flow which consists of substances that either the nutrients, oxygen and others [3] [4].

Problems that are often experienced by stroke patients and the most feared is movement disorders. Patients have difficulty walking because they experience a breakdown in muscle strength [5] [6]. Stroke is a disruption of good brain function local or global which takes place suddenly and quickly, causing clinical symptoms and signs. This disorder lasts more than 24 hours can cause death [7]. How that can be taken to reactivate the performance of hand muscles for grasping, can be done using post-stroke rehabilitation. Stroke patient will be given a post-stroke therapy to restore muscle strength of grip by providing training move your fingers first assisted by medical experts, so that over time the muscles in the fingers will be getting used to be able to grasp.

Based on the identification and problems, to see the development of his hand style value needs a "Measure Device Grip Hand Post-Stroke Patients" which can measure the force grip of post-stroke patient that the patient can see clearly the

progress in real time. In addition, patients will feel more motivated to practice because it can see the development of the value of his hand style. Motivation is a huge factor in the recovery of the Central Nervous System (CNS), so as to accelerate the recovery of the performance of nerve cells that have died.

II. MATERIALS AND METHODS

A. Research design

Ways that can be taken to reactivate the performance of the hand muscles to grasp, can be done by using post-stroke rehabilitation. Stroke sufferers will be given post-stroke therapy to restore muscle strength by grasping hands by providing training to move the fingers who was first assisted by medical experts, so that over time the muscles in the fingers will get used to being able to grasp. The study is used to measure grip force post-stroke patients, with a maximum power of 50 kg. Sambil decision taken consecutively starting load of 5 kg to 45 kg with 5 times the data penambilan.

1) Devices and materials

This study uses Loadcell type sensor rod with a maximum capacity of 50 Kg. Sensors associated with iron are used to grip. Output of Loadcell later corroborated by the modules HX711. Further into and processed into the microcontroller ADC pin. Arduino ATmega 328 as a controller and controller. Output Arduino ATmega328 form of display on LCD 2x16 Character

2) Trial

In this study, after the designs so, testing the load cell output. Researchers measure using weights with a load of 5 Kg, 10 Kg, 15 Kg, 20 Kg, 25 Kg, 30 Kg, 35 Kg, 40 Kg, 45 Kg measurements were done as much as 5x, the results seen in 2x16 character LCD. And will display the results in the form kekuatan yaitu indicator of mild, moderate, and strong

B. Block diagram

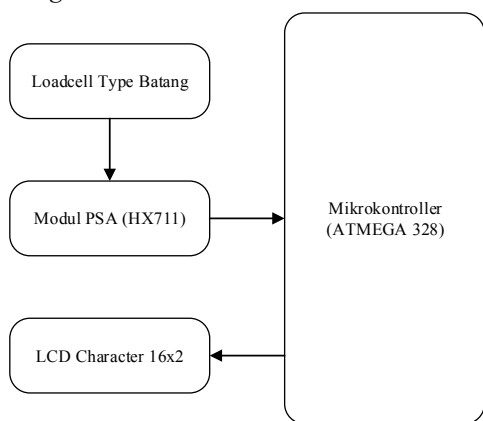

Fig. 1. The block diagram Measurement Device Grip Hand Post-Stroke Patients

When the power button is pressed, all settings so that the voltage gets ready to operate, In the writer modules made using the weight sensor. When the weight sensor a force sensor will produce a voltage. The resulting voltage sensor is very small (mV) so that the output should be amplified using amplifier circuit HX711, HX711 also serves to transform data into digital data in the form of voltage. The digital data is processed through arduino which will be displayed on the LCD display. The output of the amplifier further into the microcontroller which will then display the results in the form of numbers and power indicator.

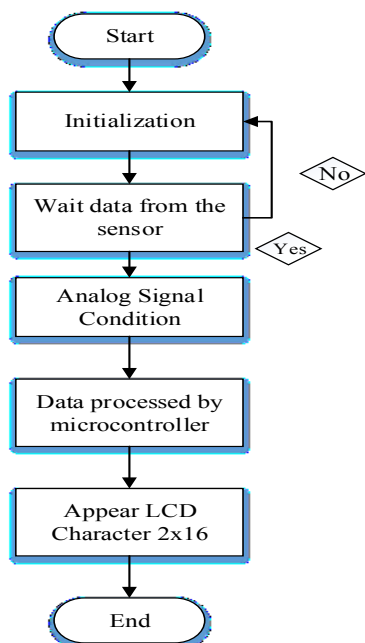

Fig. 2. The Flowchart

When the appliance is turned on it will work to initialize. Sensors work and send data then enters a series of signal conditional. Output from the signal conditional is still a

voltage is then processed by a microcontroller which is then converted into digital data is then displayed on the LCD screen.

C. series

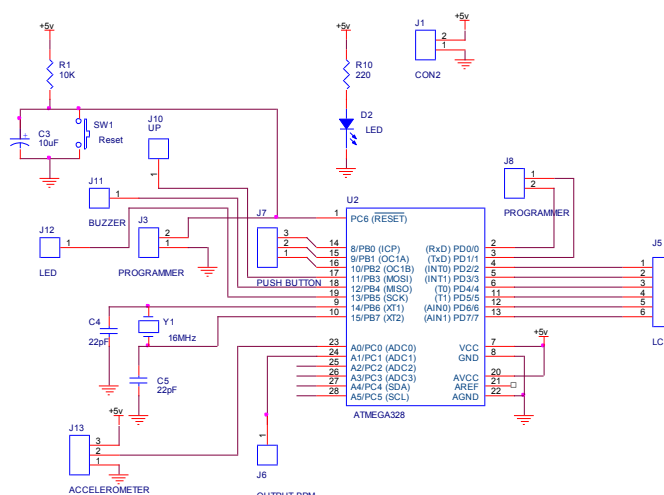

Fig. 3. Minimum System Arduino ATmega 328

Specifications module Arduino circuit ATMEGA32 minimum system required is;

1. Necessary working voltage + 5VDC and GND.
2. Requires Arduinobootloader to be able to run software compiled using the Arduino IDE.
3. Using PORTA.0 (CLK) as the CLK input module HX711.
4. Using PORTA.1 (DOUT) as input module DOUT HX711.



Fig. 4. Hx711

HX711 is weighing module, which has a working principle to convert a measurable change in a change in resistance and 9 convert it into the amount of voltage through the existing circuit. HX711 is a precision 24-bit analog- to-digital converter (ADC) designed for weigh scales and industrial control applications to interface directly with a bridge sensor[8].

III. RESULT

A. Program Arduino

```
#include <LiquidCrystal_I2C.h>
#include "HX711.h"
#define DOUT A1
#define CLK A0

float result, ref = 0;
int PBHIJAU = 7;
HX711 scale (DOUT, CLK);
float calibration_factor = 89 210
```

```
lcd.begin (16, 2);
lcd.print ( "GAUGES");
lcd.setCursor (0, 1);
lcd.print ( "POWER HAND");
delay (1000);
lcd.clear ();
delay (1000);
lcd.clear ();
lcd.begin (16,2);
lcd.print ( "BY");
lcd.setCursor (0,1);
lcd.print ( "RIA Ramadhani");
delay (1000);
lcd.clear ();
lcd.setCursor (2,0);
lcd.print ( "Press");
lcd.setCursor (5,1);
lcd.print ( "GREEN");
pinMode (PBHIJAU, INPUT);
pinMode (tarePin, INPUT);
// digitalWrite (2, HIGH);
}

void loop () {
PBHIJAU = digitalRead (7); // pushbutton
tarePin = digitalRead (6);
if (PBHIJAU == HIGH)
{
data = 1;
lcd.clear ();
}
if (tarePin == HIGH)
{
data = 2;
}
if (data == 1)
{
lcd.setCursor (0,0); // LCD choir
lcd.print ( "STRONG");
```

```
lcd.print (ref, 0);
lcd.setCursor (12,0);
lcd.print ( "kg");
scale.set_scale (calibration_factor);
result = scale.get_units ();
Serial.println (result);
if (ref <= result) {
ref = result;
}
if (ref >= result) {
ref = ref;
}
if ((ref >= 1) && (ref <= 24)) {
lcd.setCursor (0,1);
lcd.print ( "WEAK");
delay (100);
}
if ((ref >= 25) && (ref <= 31)) {
lcd.setCursor (0,1);
lcd.print ( "ARE");
delay (100);
}
if (ref >= 32) {
lcd.setCursor (0,0);
lcd.print ( "STRONG");
lcd.print (ref, 0);
lcd.setCursor (12,0);
lcd.print ( "kg");
lcd.setCursor (0,1);
lcd.print ( "POWERFUL");
delay (50);
}
}
if (data == 2)
{
scale.tare ();
data = 1;
lcd.clear ();
delay (50);
ref = 0;
```

The above program is a sensor before program initialization sensor readings. Calibration factor is obtained after calibrating the loadcell using weights whose values are traceable. Expenses in getting the use of weights.

The initial view when the device is turned on will show the name. Then when the green button is pressed and the device can be used in accordance with the power indicator displays the value stated on the 2x16 LCD. When the yellow button is pressed the value and power indicator will disappear, the yellow button is used as a reset button.

TABLE I. MEASUREMENT MODULE WITH DEVICES COMPARATIVE AND OUTPUT LOADCELL

NO	Standard	Design	Voltage (mV)
1.	5 Kg	5 Kg	00.08 mV
2.	10 Kg	10 Kg	00.15 mV
3.	15 Kg	15 Kg	00.20 mV
4.	20 Kg	20 Kg	00.31 mV
5.	25 Kg	25 Kg	00.38 mV
6.	30 Kg	30 Kg	00.44 mV
7.	35 Kg	35 Kg	00.52 mV
8.	40 Kg	40 Kg	00.60 mV
9.	45 Kg	45 Kg	00.65 mV

Below is a picture of the workmanship modules:



Fig. 5 Device When Used Respondents

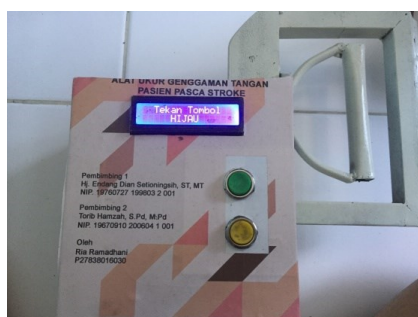

Fig. 6 Display Panel

Based on Figure 4.2 above, the display on lcd characters are the result of the hand grip and the bottom are the result of the respondent strength indicator. In addition, there are two push button that has the following caption:

Green: Start

Yellow: Reset

IV. DISCUSSION

Changes in voltage above the output obtained from measurement Load cell. The stronger the pull, the greater the voltage generated by the Loadcell. Test point measurement using a digital multimeter with selector DC mV,

V. CONCLUSION

Based on the results of the discussion and the purpose of making the module can be concluded that: a) ATmega 328p minimum system circuit can control the system properly so that the device can work as desired, b) results are displayed on the LCD according to the value weights are used as a comparison, can be interpreted program is appropriate, c) device can work when loadcell gain traction. In general, it can be concluded that the loadcell able to use the device.

REFERENCES

- [1] E. N. K. Jakob R. Mathiesen, Mette F. Bøg, Ema Erkocevic, Marko J. Niemeier, Anne Smidstrup, "Prediction of grasping force based on features of surface and intramuscular EMG," *7Th Semester Conf. Pap.*, pp. 1–9, 2010.
- [2] T. S. Buchanan, D. G. Lloyd, K. Manal, and T. F. Besier, "Neuromusculoskeletal modeling: Estimation of muscle forces and joint moments and movements from measurements of neural command," *J. Appl. Biomech.*, vol. 20, no. 4, pp. 367–395, 2004.
- [3] M. A. O. Tian, "Measurement of upper limb muscle fatigue using deep belief networks," vol. 16, no. 8, pp. 1–18, 2016.
- [4] J. V Basmajian and C. J. De Luca, "Chapter 5: Control Properties of Motor Units," *Muscles Alive: their functions revealed by electromyography*. 1985.
- [5] Y. Cahyati, E. Nurachmah, and S. P. Hastono, "Perbandingan Peningkatan Kekuatan Otot Pasien Hemiparese Melalui Latihan Range Of Motion Unilateral Pendahuluan Metode," vol. 16, no. 1, pp. 40–46, 2013.
- [6] Martini, *Fundamental of Anatomy and Physiology*, 9th ed. Boston: Pearson Education, 2012.
- [7] A. Muarandari and T. Wahyuliati, "Efikasi Fisioterapi terhadap Perbaikan Derajat Paresis Berdasarkan Status Ekonomi Penderita Stroke Based on the Economic Status," vol. 14, no. 1, pp. 33–38, 2014.
- [8] A. Semiconductor, "24-Bit Analog-to-Digital Converter (ADC) for Weigh Scales," vol. 9530, no. 592, pp. 1–10.