

Manuscript received May 18, 2022; revised August 20, 2022; accepted August 12, 2022; date of publication August 25, 2022

Digital Object Identifier (DOI): <https://doi.org/10.35882/ijahst.v2i4.96>

Copyright © 2022 by the authors. This work is an open-access article and licensed under a Creative Commons Attribution-ShareAlike 4.0 International License ([CC BY-SA 4.0](https://creativecommons.org/licenses/by-sa/4.0/))

How to cite: Rachma Prilian Eviningsih, Anggara Trisna Nugraha, and Muhammad Ilham Fatqurrochman, "Zeta Converter as a Voltage Stabilizer with Fuzzy Logic Controller Method in The Pico Hydro Power Plant", Indonesian Journal of Electronics, Electromedical Engineering, and Medical Informatics, vol. 4, no. 3, pp. 131–137, Augustus. 2022.

Zeta Converter as a Voltage Stabilizer with Fuzzy Logic Controller Method in The Pico Hydro Power Plant

Rachma Prilian Eviningsih¹, Anggara Trisna Nugraha², and Muhammad Ilham Fatqurrochman¹

¹Electrical Engineering, Politeknik Elektronika Negeri Surabaya, Surabaya 60111, Indonesia

²Marine Electrical Engineering, Shipbuilding Institute of Polytechnic Surabaya, Surabaya 60111, Indonesia

Corresponding author: Rachma Prilian Eviningsih (e-mail: rachmaevin@pens.ac.id).

ABSTRACT The development of the use of environmentally friendly renewable energy has been widely carried out, one of which is the use of energy as a turbine driver at the Pico Hydro Power Plant. The main problem in the use of energy, especially water energy is the flow of water which can affect the flow of water used to rotate the turbine so that the voltage on the DC link cannot be kept constant. Therefore, in this paper, we design and simulate the process of charging lead acid batteries with a zeta converter and a Pico Hydro Power Plant as the main source. The use of batteries in this system as energy storage if the river flow is heavy, the charging process will be carried out and if the river flow decreases, the battery will help to supply household loads. Due to the river flow which is very dependent on natural conditions, the power generated is also fluctuating so we need a control that can produce a constant output voltage from the zeta converter which is used for the battery charging process. Therefore, the aim of using a Fuzzy Logic Controller (FLC) is to keep the output voltage of the zeta converter constant so that it can maintain battery life. The results obtained in the close loop simulation test are a constant output voltage of 14.4 V and an output current of 6.64 A so that it can be used for the battery charging process that will be used for household lighting.

INDEX TERMS FLC, Pico Hydro Power Plant, Zeta Converter.

I. INTRODUCTION

New and Renewable Energy (NRE) is energy that comes from natural processes that are replenished continuously and in a sustainable manner that can continue to be produced without having to wait millions of years like fossil-based energy and has been widely used by humans in modern times as a substitute for fossil energy [1].

NRE is classified into 2, namely New Energy (NE) and Renewable Energy (RE). The term NRE is often mentioned on various occasions, including Law No. 37 of 2007 on Energy, Law No. 30 of 2009 on Electricity, and Government Regulation No. 79 of 2014 on National Energy Policy. However, the three laws make NE and RE into one unit so it has the implication that the two types of energy have the same position, namely as the energy that should be supported and prioritized and given incentives for its development. However,

NE and RE have very different meanings. "New Energy (NE)" is artificial energy produced from new technology. Most of the NE comes from further processing of non-renewable energy, such as liquefied coal so the impact generated in the development of new energy types of liquefied coal can affect the quality of water sources. In contrast to ENE, "Renewable Energy (RE)" is the energy obtained from the earth's unlimited and inexhaustible natural resources and has absolutely nothing to do with non-renewable energy, for example, hydropower, solar power, etc. Therefore, these two types of energy should not be confused.

The use of RE is indeed considered more environmentally friendly because it can reduce environmental pollution and environmental damage when compared to non-renewable energy because RE is fast enough to be recovered naturally.

This means that RE is generated from energy resources that nature will not be depleted and can be sustainable if managed properly. Therefore, RE can also be referred to as sustainable energy, and of the many types of RE such as sunlight, wind energy, and water energy is one of the renewable energies that can be utilized [2].

The potential for water energy utilization has begun to be widely used by the community, especially to meet the needs of electrical energy in remote, rural areas, and has also been developed for an interconnection system with the existing PLN network. In addition, one of the uses of water energy that has begun to be developed is to produce small-scale electrical energy or commonly known as the Pico Hydro Power Plant which uses water power as a driving force to turn a turbine. This type of generator is very appropriate to be applied to areas that are difficult to reach by the electricity network [3-4].

The main problem with using RE energy as alternative energy, especially water energy, is that it depends on weather conditions and also the flow of water used to rotate the turbine at the Pico Hydro Power Plant, causing the voltage on the DC link cannot be kept constant. [5-6] In addition, there are still not many studies that discuss methods and systems that are suitable for keeping the voltage on the DC link constant. Therefore, in this paper, we will design and simulate the charging process for a lead acid battery with a DC-DC converter and a Pico Hydro Power Plant as the main source. The type of generator used in the Pico Hydro Power Plant is a DC generator with an output voltage of 9-18 Volts at 150-360 rpm. The output voltage of the DC generator is still fluctuating, so to maintain a constant voltage value, a DC-DC converter is needed, one of which is a zeta converter. A zeta converter is a type of converter that can produce an output voltage that can be higher or lower than the input voltage without reversing the polarity. The zeta converter is supplied with a voltage. Input from a DC generator will be used to charge the battery. The use of batteries in this system as an energy store is due to the water discharge from the canal as the driving force of the mill at some point due to the alternate use of water flowing into the irrigation canal. The aim of using a fuzzy logic controller in this system is to keep the output voltage on the zeta converter constant so that it can be used for the battery charging process and the battery life can be used for a long time. In addition, to test whether the control used has worked well, it will be compared to using the PI control.

II. THE MODELLING OF THE PICO HYDRO SYSTEM

The configuration of the Pico Hydro Power Plant system connected to the battery is shown in Figure 1. This system consists of a DC generator as a voltage source. Then the DC generator output voltage will be forwarded to the zeta converter so that it can charge the battery so that a stable output voltage is needed. Therefore, to keep the zeta converter output voltage stable, a fuzzy logic controller algorithm is applied to the system.

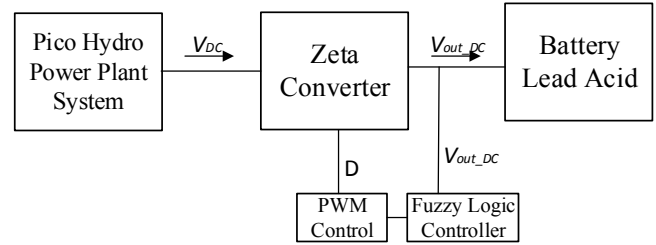

FIGURE 1. The Diagram Block of Pico Hydro Power Plant

A. PICO HYDRO POWER PLANT

Pico Hydro is a term used for power plant installations that use water energy on a small scale. Water conditions that can be used as electricity-producing resources are those that have a certain flow capacity and height and installation. The small-scale power plant can use hydropower in irrigation canals and rivers or natural waterfalls, by utilizing the height of the falls (head, in m) and the amount of water discharge (m^3/second). [6]

The greater the flow capacity and height of the installation, the greater the energy that can be used to generate electrical energy. This Pico Hydro Power Plant is a power plant with the working principle of river water passing through the waterwheel and then turning the waterwheel. Mechanical energy from the rotation of the waterwheel will be converted into electrical energy by a DC generator. The Pico Hydro Power Plant used in this paper uses a DC generator with the specifications presented in Table I.

TABLE 1
 Specification of DC Generator

Parameter	Value
Output Voltage	9 - 18 Volt
Maximum Output Power	150 Watt
Maximum Output Current	8.33 A
Size (PxL)	11 × 8 cm
Diameter ass/sef	8 mm
Line to line resistance	$10.5 \pm 0.5 \Omega$
Generator life	$\geq 3000h$

B. ZETA CONVERTER

A zeta converter is a type of fourth-order DC-DC converter that can increase or decrease the output voltage without having to change the polarity of the output converter as well as the SEPIC converter [7-11]. The zeta converter has the same capability as the buck-boost converter which can increase or decrease the value of the output voltage but has the advantage that the output polarity is not reversed. The inductors and capacitors in this converter have a large effect on the efficiency of the converter and the ripple of the resulting voltage. This converter transfers energy between its inductance and capacitance to convert from a voltage energy quantity to another energy quantity [12-16]. The energy transfer process is controlled by a switching SW (MOSFET).

The schematic of the zeta converter can be shown in Figure 2.

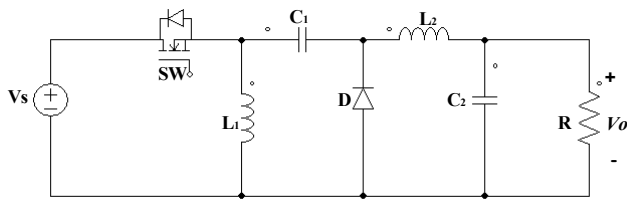

FIGURE 2. The Circuit of Zeta Converter

Equations (1) to (5) are used to model the zeta converter so that it can work in continuous conduction mode (CCM). The relationship between the output voltage (V_o) and the input voltage (V_s) to get the value of the duty cycle (D) using equation (1).

$$D = \frac{V_o}{V_o + V_s} \quad (1)$$

Meanwhile, to get the value of the inductor (L) and capacitor (C) on the zeta converter, it can be expressed by equations (2) to (5).

$$L_1 = \frac{1}{2} \frac{D \times V_s}{\Delta i_{L1} \times f} \quad (2)$$

$$L_2 = \frac{1}{2} \frac{D \times V_s}{\Delta i_{L2} \times f} \quad (3)$$

$$C_1 = \frac{D \times I_{out}}{\Delta V_{CC} \times f} \quad (4)$$

$$C_2 = \frac{\Delta i_{L2}}{8 \times \Delta V_o \times f} \quad (5)$$

In this system, the zeta converter is used to maintain the output voltage of the DC generator to match the voltage required for charging the battery, with the help of a fuzzy logic controller so that the output voltage of the zeta converter will be maintained stable. The parameter of zeta converter is shown in Table II.

TABLE 2
 The Parameter of Zeta Converter

Parameter	Symbol	Value	Unit
Input Voltage	V_s	15 - 18	V
Output Voltage	V_o	14.4	V
Switching Frequency	f	40	kHz
Duty cycle	D	49	%
Input Current	I_s	8.33	A
Output Current	I_o	6.6	A
Inductor 1	L_1	110.29	μ H
Inductor 2	L_2	139.21	μ H
Capacitor 1	C_1	561.46	μ F
Capacitor 2	C_2	14.32	μ F

C. FUZZY LOGIC CONTROLLER

Fuzzy logic was proposed by Lofti Zadeh in 1965, as a tool to deal with uncertainty and imprecise or qualitative decision-

making control problems. This type of controller combines intelligent and conventional intelligent control of complex dynamic systems. Fuzzy logic control is a control algorithm based on linguistic control strategies in automatic control strategies. [17-20]

Fuzzy Logic Controller maps an input space into an output space which has classical logic which states that anything can be expressed in binary terms (0 or 1, yes or no). Fuzzy logic allows membership values between 0 and 1, gray levels as well as black and white, and in linguistic terms, uncertain concepts such as "a little", "fair", and "a lot". [21-23] In fuzzy logic, linguistic values and expressions are used to describe physical variables. The block diagram of the fuzzy logic controller can be seen in Figure 3.

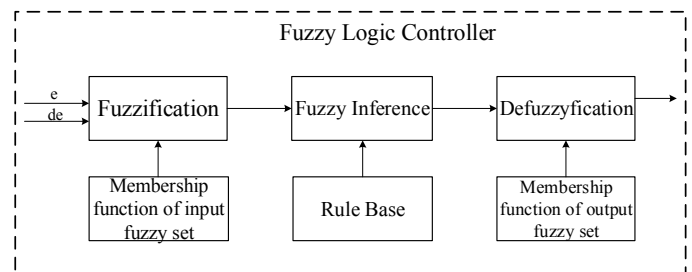

FIGURE 3. Block Diagram of Fuzzy Logic Controller

Fuzzy logic control means open and closed loop control of technical processes, including the processing of measured values, derived from measured variables, and set points. [24-25] The general structure of the FLC controller consists of the following:

a. Fuzzification

Fuzzification is the process of transforming the input crisp values into fuzzy values (linguistic variables) which are presented in the form of a fuzzy set with each membership function. Before designing a membership function, what should be done is to look at the system response in an open loop so that it can be used to determine the number of crisp inputs and the number of membership functions.

b. Rule Base

To determine the rule base on the fuzzy control that will be used in this paper, the "if-then" statement describes the actions taken in response to various inputs from the fuzzy control. These rules can be written in matrix form and from 7 membership functions input error and delta error, 49 rules can be generated that can determine the output value of the singleton value response to be taken.

c. Defuzzification

The output of the rule base is in the form of a fuzzy value. So, the defuzzification process is needed to transform a linguistic variable into a value in the form of a duty cycle which is used to adjust the switching of the MOSFET zeta converter. In making the membership function output, the way

to enter the value is the same as the step to enter the membership function input.

One of the functions of the control is to minimize the error signal. The signal error is the difference between the desired quantity and the actual value. In this scheme, the set point on the fuzzy logic controller control is the charging voltage value of 14.4 V, then the control input in the scheme is error and delta error, while the output is to maintain the stability of the charging voltage.

In this paper, we use a membership function in the form of a singleton (also known as Sugeno) which only has one input value. Membership function output has 7 types of singletons, which represent the value of Negative Big (NB), Negative Medium (NM), Negative Small (NS), Zero (Z) which has a value of 0, Positive Small (PS), Positive Medium (PM), Positive Big (PB).

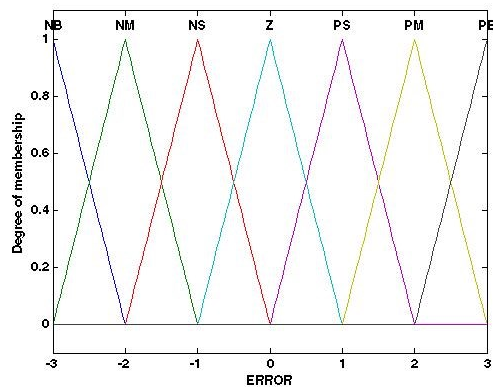

FIGURE 4. Error Membership Function

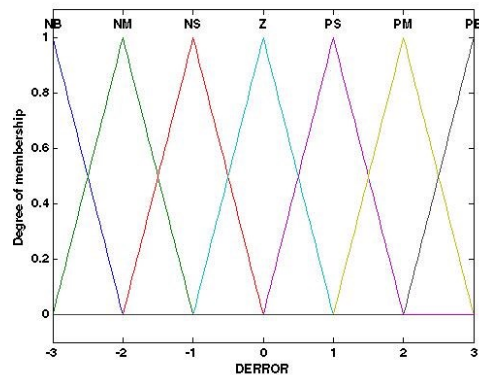

FIGURE 5. Membership Function Delta Error

This paper also uses two inputs, namely error, and delta error. error is the difference in value between the reference voltage and the voltage value read by the sensor, if the error is negative, the output voltage value of the zeta converter is too large compared to the set point voltage, then the zeta converter output voltage needs to be lowered. Conversely, if the error value is positive, it means that the zeta converter output voltage is too small compared to the set point voltage, then the

zeta converter output voltage needs to be increased. While the delta error is the difference in value between the current error and the previous error. As well as one output which will later regulate the amount of PWM duty cycle for switching in the zeta converter circuit. The input membership function uses a triangular shape as shown in Figure 4 and Figure 5. The input membership function limits, on the input side, are divided into two, namely input error and delta error with a limit range for input error of -3 to 3 Volts, while for the Input delta error range which is equal to -3 to 3 Volts.

The inference is a decision-making process on the fuzzy concept. The membership degrees generated from the previous process are combined based on certain rules (rule base). The rule base shows the relationship between the input, namely error and delta error with the output which will regulate the amount of the duty cycle, the output will change according to the value of the two inputs. The rule base planning used in this study can be seen in Table III.

TABLE 3
 RULE BASE

$E/\Delta E$	NB	NM	NS	Z	PS	PM	PB
NB	NB	NB	NM	NM	NM	NS	Z
NM	NB	NM	NM	NM	NS	Z	PS
NS	NM	NM	NM	NS	Z	PS	PM
Z	NM	NM	NS	Z	PS	PM	PM
PS	NM	NS	Z	PS	PM	PM	PM
PM	NS	Z	PS	PM	PM	PM	PB
PB	Z	PS	PM	PM	PM	PB	PB

III. SIMULATION RESULTS AND DISCUSSION

Figure 6 is a series of the entire Pico Hydro Power Plant system used in this paper with the parameters that have been determined in the system modeling section. Simulations are carried out to carry out the battery charging process on the battery with the constant voltage method to keep the battery from being over-charged, by maintaining the zeta converter output voltage which has been controlled by a fuzzy logic controller so that the zeta converter output voltage becomes stable according to the desired charging voltage and Safe to use in the battery charging process. In this system, the battery is used with a capacity of 33 Ah 12 V.

A. OPEN LOOP SIMULATION RESULTS

Open loop integration testing is a test of the entire system without control. The purpose of this test is to determine the characteristics of this system. In this system, it consists of a DC generator as the main source, then the output voltage from the DC generator will be regulated by the zeta converter manually with the duty cycle value that has been calculated in the previous zeta converter planning.

This open loop integration test is done by simulation. This system consists of a zeta converter connected to a load resistor which will be tested in an open loop. Simulation data retrieval

is done by changing the voltage value of the 15 Volt DC generator with a duty cycle that varies from 10% to 90%. The

results of the open loop system integration test are shown in Table IV.

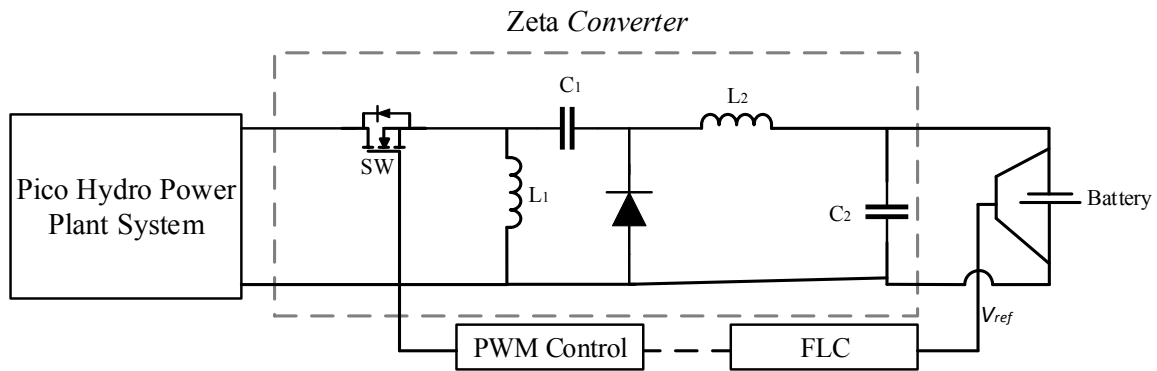

FIGURE 6. The Circuit of Pico Hydro Power Plant System

TABLE 4
 Loop Open Loop Simulation Test Result Data

Duty Cycle (%)	V_{in} (V)	I_{in} (A)	V_{out} Theory (V)	V_{out} Simulation (V)	I_{out} (A)
10	15	0.01	1.67	1.67	0.76
20	15	0.45	3.75	3.75	1.72
30	15	1.22	6.43	6.43	2.95
40	15	3.09	10	10	4.68
49	15	1.42	14.4	14.4	6.6
50	15	6.71	15	14.9	6.87
60	15	15.54	22.5	22.5	10.31
70	15	36.74	35	34.9	16.04
80	15	110.13	60	59.9	27.4
90	15	546.93	135	134.5	61.66

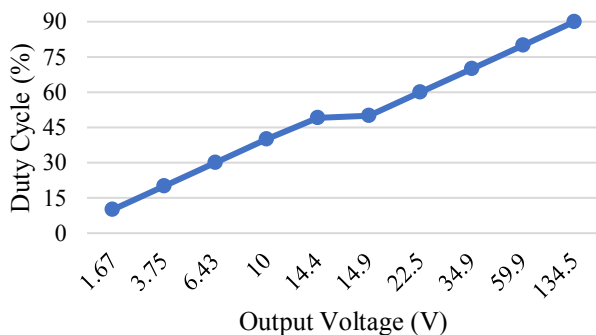

FIGURE 7. Graph of output voltage to duty cycle

From the simulation results shown in Table IV, it can be concluded that when testing the integration with a DC generator source, the zeta converter has been able to produce an output voltage of 14.4 V with an output current of 6.61 A at a duty cycle of 49% so that it is by the previous plan.

If seen in Figure 7, it is a graph between the output voltage to the duty cycle with an input voltage of constant value. From Figure 7 it can be seen that the zeta converter can already work according to its work function, which is to increase and decrease the output voltage because with a constant input

voltage of 15 V when the duty cycle is below 50 % it produces a smaller output voltage, whereas when the duty cycle is above 50% with an input voltage of 15 V it can produce a larger output voltage.

B. CLOSED LOOP SIMULATION RESULTS WITH FUZZY LOGIC CONTROLLER

Closed loop simulation testing is a test on the Pico Hydro Power Plant system using the controls that have been designed in this paper. In Figure 6 the zeta converter is connected to the Pico Hydro Power Plant system and for the load, it uses a 33 Ah 12 V battery. To find out if the designed Fuzzy Logic Controller is working well, then the simulation data retrieval is carried out with the planned setpoint voltage of 14.4 Volts.

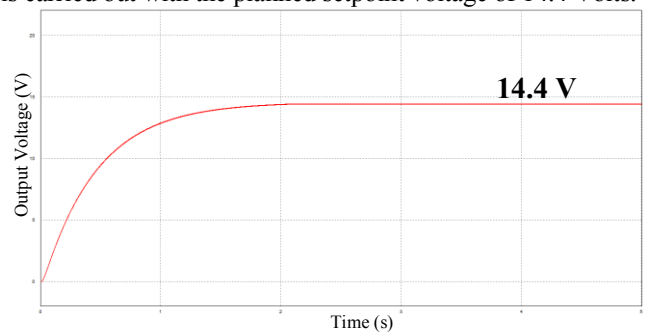

FIGURE 8. Output Voltage Simulation Waveform on Pico Hydro Power Plant System using FLC

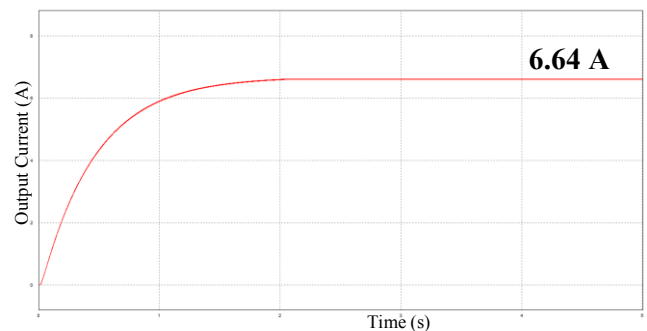

FIGURE 9. Output Current Simulation Waveform on Pico Hydro Power Plant System using FLC

Figure 8 is the output voltage waveform on the Pico Hydro Power Plant system as a whole which was tested in a close loop and has been able to produce an output voltage of 14.4 Volts. While in Figure 9 is the output current wave on the Pico Hydro Power Plant system as a whole which was tested in a close loop and was able to produce an output current of 6.64 A. Based on the simulation results, the output voltage response when using the Fuzzy Logic Controller was able to produce an output voltage that has a constant value and is also in accordance with the tests that have been carried out during the open loop with a duty cycle of 49%.

C. CLOSED LOOP SIMULATION RESULTS WITH VARIATION OF INPUT VOLTAGE

Closed loop simulation testing by varying the output voltage of the Pico Hydro Power Plant System starting from 14.7 V; 18V; and 15.9 V as shown in Figure 10. This aims to test the Fuzzy Logic Controller control which is designed to work according to the design that has been made so that the output voltage after the zeta converter can be constant at 14.4 Volts so that it can be used to carry out the battery charging process.

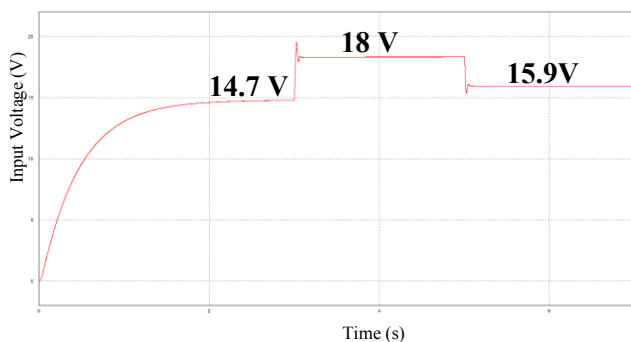

FIGURE 10. Input Voltage Waveform on Pico Hydro Power Plant System

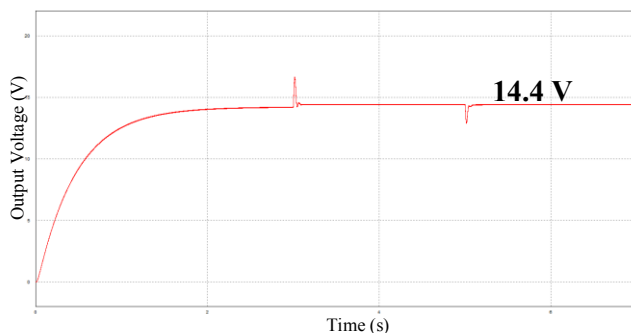

FIGURE 11. Output Voltage Simulation Waveform on Pico Hydro Power Generation System using FLC with Variation of Input Voltage

In Figure 11, the output voltage waveform on the Pico Hydro Power Plant System as a whole is tested in a close loop using a Fuzzy Logic Controller by varying the input voltage on the DC Generator and it turns out that the results obtained from the simulation are that the output voltage remains stable at

14.4 Volts. as shown in Figure 10 so that it can carry out the charging process on the battery. From the simulation results that have been carried out, it can be proven that the use of controls that have been previously designed can still produce stable output voltages and currents by planning.

D. COMPARISON OF CLOSED LOOP SIMULATION RESULTS USING PI AND FUZZY LOGIC CONTROLLER

To prove that when closed-loop testing using fuzzy control on the Pico Hydro Power Plant System is considered successful, it will be compared using PI control. The results of the simulation test using the PI control can be shown in Figure 12.

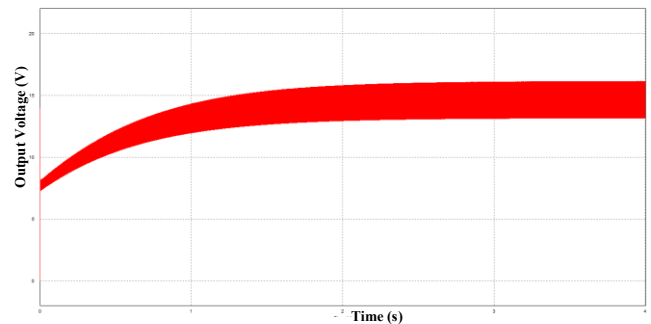

FIGURE 12. Output Voltage Simulation Waveform on Pico Hydro Power Plant System using PI

From Figure 12, if we compare it with Figure 8, it can be concluded that when the Pico Hydro Power Plant system uses PI control, there is still a very large output voltage ripple, and also the time to reach steady state conditions for 3 seconds. It is different when using FLC control, the output voltage ripple is less and it only takes 2 seconds to reach a steady state.

IV. CONCLUSION

Based on the simulation results of battery charging using a constant voltage method using a fuzzy logic controller, it is certain that the Pico Hydro Power Plant system as a whole using fuzzy logic controller control can maintain the value of the voltage required for the battery charging process with a capacity of 33 Ah 12 V. The average voltage value of the zeta converter can be stable in the range of 14.4 V and a current of 6.64 A and this is in accordance with the design that has been made. And if we compare the simulation results between using PI control and fuzzy logic controller, it can be concluded that the fuzzy logic controller is better because the output voltage ripple is less and it also doesn't take long to reach steady state conditions.

This study has a weakness in that it only compares 2 different methods. So, it has limitations on the data obtained only on these 2 methods without testing other control systems. Therefore, this research can be completed again by using several other control methods to get the best control system results for the Pico Hydro Power Plant system.

REFERENCES

- [1] Zakariz, Naufal Praska, Anggara Trisna Nugraha, and Khongdet Phasinam. "The Effect of Inlet Notch Variations in Pico-hydro Power Plants with Experimental Methods to Obtain Optimal Turbine Speed." *Journal of Electronics, Electromedical Engineering, and Medical Informatics* 4.1 (2022): 35-41.
- [2] Nugraha, Anggara Trisna, and Dadang Priyambodo. "Design of Hybrid Portable Underwater Turbine Hydro and Solar Energy Power Plants: Innovation to Use Underwater and Solar Current as Alternative Electricity in Dusun Dongol Sidoarjo." *Journal of Electronics, Electromedical Engineering, and Medical Informatics* 3.2 (2021): 93-98.
- [3] S. Bandyopadhyay, V. Valsan and P. Kanakasabapathy, "Operation Analysis of Grid Integrated Solar Micro Hydro Hybrid System for Rural community," 2021 IEEE 2nd International Conference on Electrical Power and Energy Systems (ICEPES), 2021, pp. 1-6, doi: 10.1109/ICEPES52894.2021.9699690.
- [4] Robert Agyare Ofosu, E. Normanyo, K. K. Kaberere, S. I. Kamau & E. K. Out, 2022, "Design of an Electronic Load Controller for Micro Hydro Power Plant Using Fuzzy-PI Controller". *Cogent Engineering*, 9:1, DOI: 10.1080/23311916.2022.2057115
- [5] Melese Loha Anjulo, 2019, "Power Management of Standalone Hybrid PV-Micro Hydro Battery Energy Storage System using Fuzzy Logic Controller", INTERNATIONAL JOURNAL OF ENGINEERING RESEARCH & TECHNOLOGY (IJERT) Volume 08, Issue 07 (July 2019)
- [6] P. D. Singh and S. Gao, "A New Scheme of Micro Hydro Power Generation Using AC-DC-AC Converter and Parallel Asynchronous Generators with Variable Turbines," 2020 IEEE International Conference on Power Electronics, Smart Grid and Renewable Energy (PESGRE2020), 2020, pp. 1-6, doi: 10.1109/PESGRE45664.2020.9070651.
- [7] Sunarno, E., Sudiharto, I., Nugraha, S. D., Murdianto, F. D., & Qudsi, O. A., "Design and implementation bidirectional SEPIC/ZETA converter using Fuzzy Logic Controller in DC microgrid application." *Journal of Physics: Conference Series*. Vol. 1367. No. 1. IOP Publishing, 2019.
- [8] A. Rizqi and E. Wahjono, "Implementasi Maximum Power Point Tracking Berbasis Fuzzy Logic Controller Dengan Zeta Converter," no. April, pp. 36–44, 2021.
- [9] Alia M. Khatib, "An Electric Vehicle Battery Charger Based on Zeta Converter Fed from a PV Array", IEEE- International Conference on Environment and Electrical Engineering and 2018 IEEE Industrial and Commercial Power Systems Europe (EEEIC / I&CPS Europe).
- [10] Omnia S. S. Hussian, Hany M. Elsayed, M. A. Moustafa Hassan, 2019, "Fuzzy Logic Control for a Stand-Alone PV System with PI Controller for Battery Charging Based on Evolutionary Technique" in The 10th IEEE International Conference on Intelligent Data Acquisition and Advanced Computing Systems Technology and Applications, Metz, France 18-21.
- [11] R. Ragul, N. Shanmugasundaram and R. Krishnakumar, "PV System with Zeta Converter using ANFIS Controller based GWO Optimization," 2022 International Conference on Electronics and Renewable Systems (ICEARS), 2022, pp. 366-370, doi: 10.1109/ICEARS53579.2022.9752008.
- [12] S. Chauhan and H. Singh, "Design and Control of Zeta Converter Based PMBLDC Motor drive for Solar Water Pumping Application," 2021 International Conference on Communication, Control and Information Sciences (ICCISc), 2021, pp. 1-5, doi: 10.1109/ICCISc52257.2021.9484943.
- [13] D. Rastogi, M. Jain and M. Sreejeth, "Comparative Study of DC-DC Converters in PV Systems Using Fuzzy Logic MPPT Algorithm," 2022 IEEE Delhi Section Conference (DELCON), 2022, pp. 1-7, doi: 10.1109/DELCON54057.2022.9753494.
- [14] Hart, Daniel W. 2011, "Power Electronics" America: Mc Graw Hill.
- [15] Nugraha, Anggara Trisna and Rachma Prilian Eviningsih. 2020, "Penerapan Sistem Elektronika Daya: AC Regulator, DC Chopper, dan Inverter" Yogyakarta: Deepublish
- [16] Nugraha, Anggara Trisna and Rachma Prilian Eviningsih. 2020, "Konsep Dasar Elektronika Daya" Yogyakarta: Deepublish
- [17] M. Z. Abdullah, I. Sudiharto and R. P. Eviningsih, "Photovoltaic System MPPT using Fuzzy Logic Controller," 2020 International Seminar on Application for Technology of Information and Communication (iSemantic), 2020, pp. 378-383, doi: 10.1109/iSemantic50169.2020.9234200.
- [18] A.R. Nansur, A.S.L. Hermawan, F.D. Murdianto, "Constant Voltage Using Fuzzy Logic Controller (FLC) to Overcome the Unstable Output Voltage of MPPT in DC Microgrid System," 2018 Int. Electronics Symposium on Engineering Technology and Applications (IES-ETA), 2018, hal. 19-24.
- [19] A.R. Wachid, E. Wahjono, S.D. Nugraha, "Design and Simulation of Dual Input Single Output Buck Converter with Fuzzy Control", *Jurnal Nasional Teknik Elektro dan Teknologi Informasi*, Vol. 10, No. 1, Februari 2021, hal 63-70.
- [20] Sutikno, T., Wahid, S. H., Aprilianto, R. A., Subrata, A. C., & Jidin, A. (2022), "An Automatic Wind Turbine Braking System on PLTH Bayu Baru through a Fuzzy Logic Controller", *JURNAL NASIONAL TEKNIK ELEKTRO*, 11(1), 1–7.
- [21] J. A. Al-Dmour, A. Sagahyroon, A. Al-Ali, and S. Abusnana, "A fuzzy logic-based warning system for patients classification," *Health Informatics J.*, vol. 25, no. 3, pp. 1004–1024, Sep. 2019, doi: 10.1177/1460458217735674.
- [22] M. Metwally Mahmoud, H. S. Salama, M. M. Aly, and A.-M. M. Abdel-Rahim, "Design and implementation of FLC system for fault ride-through capability enhancement in PMSG-wind systems," *Wind Eng.*, vol. 45, no. 5, pp. 1361–1373, Oct. 2021, doi: 10.1177/0309524X20981773.
- [23] M. Kesraoui, S. A. Lagraf, and A. Chaib, "Aerodynamic power control of wind turbine using fuzzy logic," in 2015 3rd International Renewable and Sustainable Energy Conference (IRSEC), Dec. 2015, pp. 1–6, doi: 10.1109/IRSEC.2015.7455110.
- [24] M. H. Azam, M. H. Hasan, S. Hassan, and S. J. Abdulkadir, "Fuzzy Type-1 Triangular Membership Function Approximation Using Fuzzy C-Means," in 2020 International Conference on Computational Intelligence (ICCI), Oct. 2020, no. October, pp. 115–120, doi: 10.1109/ICCI51257.2020.9247773.
- [25] H. L. Sari, T. U. Kalsum, and D. Mahdalena, "The Implementation of Fuzzy Multiple Attribute Decision Making by Using Weighted Product Algorithm in Evaluating Employees' Performance," *J. Phys. Conf. Ser.*, vol. 1255, no. 1, p. 012093, Aug. 2019, doi: 10.1088/1742-6596/1255/1/012093.