

Manuscript received October 30, 2021; revised March 3, 2022; accepted April 21, 2022; date of publication May 30, 2022

Digital Object Identifier (DOI): <https://doi.org/10.35882/ijeemi.v4i2.2>

This work is an open-access article and licensed under a Creative Commons Attribution-ShareAlike 4.0 International License ([CC BY-SA 4.0](https://creativecommons.org/licenses/by-sa/4.0/))



# Analysis of Drop Sensor Accuracy in Central Infusion Peristaltic Monitoring Based on Computer Using Wireless Communication HC-11

Syaifudin<sup>1</sup>, Triana Rahmawati<sup>1</sup>, Siti Rohmatul Jannah<sup>1</sup>, Sandeep Kumar Gupta<sup>2</sup>, Ram Gopal<sup>3</sup>

<sup>1</sup> Department of Medical Electronics Technology, Poltekkes Kemenkes Surabaya, INDONESIA

<sup>2</sup> IIMT College of Engineering, INDIA

<sup>3</sup> Department of Electronics & Communication Engineering, Institute of Technology & Management, Gorakhpur, INDIA

Corresponding Author: Triana Rahmawati (e-mail: [triana@poltekkesdepkes-sby.ac.id](mailto: triana@poltekkesdepkes-sby.ac.id))

**ABSTRACT** In some hospitals, the infusion is still done manually, where medical personnel observe the liquid droplets directly and then control the rate using a mechanical resistor (clamp). This method is certainly far from accurate. An infusion pump is a medical aid that functions to control and ensure the correct dose of infusion fluid given to patients treated. The purpose of this study was to analyze the accuracy of the infrared photodiode as a drop sensor based on the readings of the infusion pump monitoring system. This module consists of a photodiode infrared drop sensor module, a comparator circuit, a monostable circuit, a stepper motor, an L298N motor driver, and an ATmega328 microcontroller. The droplets were detected by an infrared photodiode sensor, then compared with a comparator and monostable circuit as an oscillator developer, and then the flow rate and residual volume readings were generated by the ATmega328 microcontroller. Next, this data has sent to the computer via the HC-11 wireless. The results of the flowrate module measurement show the highest error value of 3% at the 30 ml/hour setting and the lowest error value of 2.5% at the 60 ml/hour setting. Meanwhile, the results of the flow rate measurement using an infusion device analyzer obtained the highest error value of 4% at the setting of 30 ml/hour and 60 ml/hour, and the lowest error value of 0.8% at the setting of 100 ml/hour. Monitoring the infusion pump was designed centrally to facilitate the nurse's task in monitoring the infusion dose given to the patient accurately. Based on this research, the accuracy of the infrared sensor and photodiode is very good by looking at the existing error rate.

**INDEX TERMS** Infusion Pump, Central Monitoring, phododida-infrared, Wireless.

## I. INTRODUCTION

Infusion Pump is a medical aid to control and ensure the correct dose of intravenous fluids given to patients treated. In the setting of a manual infusion system, the clinician observes the droplet directly and controls its rate using a mechanical resistor (clamp) [1]. Manual infusion systems fill critical gaps in low-resource settings but are less than optimal, as they are

more labor-intensive, less reliable, may require expensive single-use equipment, and some systems lack flow rates and dose adjustment [2] [3]. These factors are critical barriers in providing effective and high-quality medical care in cases where punctuality and dosage are critical [4], as user acceptance of the technology is strongly influenced by how users perceive technical performance (including factors such

as system reliability, speed, and accuracy)[5][6]. Incorrect administration rates have been consistently shown to be the most significant problem in intravenous drug administration [7][8][9][10]. Concerns were also raised that some of the incorrect rate errors were caused by poor computational skills [7][11]. The clinician at the point of care, most often the nurse, is responsible for the final step to ensure that the correct intravenous or infusion drug is administered [12]. The development and modification of nursing actions, especially in the setting of intravenous fluid administration, needs to be done [13]. Serious patient outcomes are over-represented among intravenous drug administration errors compared to other adverse incidents [9][12]. A study in 2005 found a staggering of 67% error rate with intravenous infusion in the intensive care unit (ICU) [13][14]. Data support that up to 58% of all intravenous errors occur during the steps of actual drug delivery, again relying on the human end user at the human-device interface as the final step in ensuring safety [13]. The infusion pump is one of the developments of medical devices that function to automatically insert intravenous fluids into the patient's body. This tool has a fairly important function in medical services, especially in the care of critical patients. Often in a hospital, the number of patients is not balanced with the number of nurses, so the negligence in monitoring the condition of the patient's infusion fluid is possible. In addition to the modifications determined by the US Food and Drug Administration (FDA) that would not create an undue risk of covid, "remote monitoring and manual control of infusion pumps to manage patient care without physically entering the patient's room" is needed [10][15][16][17]. Therefore, we need a tool that can monitor the use of infusions centrally in hospitals to overcome this problem, so that the duties of nurses can be simplified while also maintaining personal safety [15][18][13]. Pattarakamon

Rangsee has designed a drop sensor monitoring system, but this research was focused on the data transmission system, instead of discussing the accuracy of the sensors used [19]. KK Thariyan conducted a research on infusion pump sensors using 3 sensors but the accuracy level is unknown [20]. Furthermore, research has been carried out by Hanna Firdaus, namely a central infusion monitor system with volume and droplet detection parameters per minute using the TCRT-5000 sensor with an error of 4% at a flow rate of 30 ml/s [21]. After that, in 2019 a relevant study was conducted by Matthew Taylor regarding the risk of medication errors with infusion pumps, where drug orders may have incorrect or conflicting level or dose information, misinterpreted transcription of drug orders, incorrect laboratory test results lead to incorrect levels, and smaller or larger drugs volume prepared than ordered [16]. S. Ssekitoleko has also conducted research using photo cell sensors, but this research was not designed in a centralized manner [19]. Karen K did research on smart systems on infusion pumps, but the sensors used still have a fairly high error [22]. Shiyong Zheng conducted a research on detecting drip rates on infusion pumps but the results or the resulting error rate were not visible. [23]. Qiliang Du simulated liquid detection with infrared. Based on this simulation, it proved that infrared was effectively used to detect liquid droplets [24]. Shohag Hossain further monitored the rate of infusion fluid by using an infrared sensor while using a smartphone to monitor it. Through the use of a smartphone, you will have a limited number of limitations that are monitored [25].

Based on the problems above, a study was conducted on the accuracy of the fall sensor in the infusion pump with centralized monitoring. The purpose of this study was to obtain an analysis of the accuracy of the fall sensor (photodiode infrared) at the peristaltic infusion monitoring

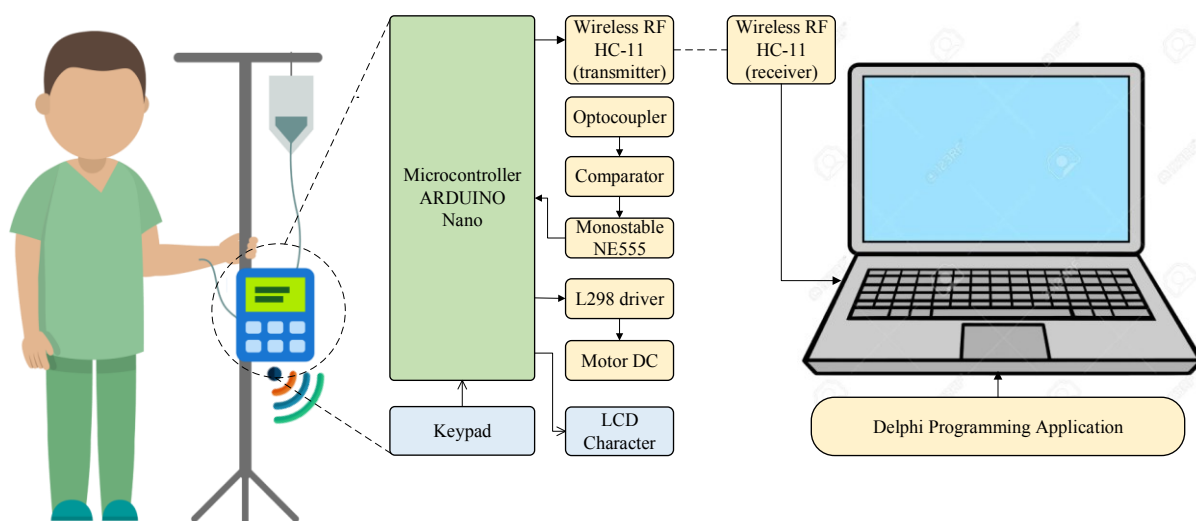

FIGURE 1. The Diagram Block of the Infuse Pump Monitoring using wireless communication based on HC-11 from microcontroller as transmitter to Personal Computer as receiver

center displayed on a wireless-based computer. In building the system, several constituent components are needed such as peristalsis on the mechanical infusion pump, infrared photodiode sensor for detection of infusion liquid droplets, HC-11 module as a wireless concept in the design.

## II. MATERIALS AND METHOD

### A. EKSPERIMENTAL SETUP

This study used a flow rate setting of 30 ml/hour, 60 ml/hour, and 100 ml/hour with a volume of 500 ml infusion fluid. The readings on the infusion pump are sent to a computer via wireless HC-11. The data viewer on the computer uses the Delphi application which contains the drop rate, volume, and flow rate graphs. The flow rate value can be stored on the computer in excel format, and the flow rate graph can be stored in the form of an image.

#### 1) MATERIALS AND TOOL

The study used an infusion set of Terumo with a specification of 20 drop/1ml, 500 ml volume infusion, photodiode-infrared sensor circuit as drop detection, comparator circuit using LM741OP-AMP and monostable using IC NE555, L298N motor driver module for stepper motor driver, Atmega835 microcontroller as data processor and stepper motor speed controller. In addition, HC-11 wireless module for data communication on computer, oscilloscope with digital storage (Textronic, DPO2012, Taiwan) to retrieve test point data on analog circuits as well as an infuse device analyzer or IDA Rigel used for flowrate and volume data retrieval were also utilized.

#### 2) EXPERIMENT

In this study, after the module design was completed, the drop sensor was tested by calculating the number of drop rates (drops per minute) at each setting and comparing it with the drop rate results (drops per minute) on the display module. Furthermore, a comparison of the readings of the flow rate and volume results on the display module was carried out with measurements using IDA (Infusion Device Analyzer). In performing the calibration, the infusion pump flow rate settings used were 30 ml/hour, 60 ml/hour, and 100 ml/hour. Measurement results on IDA were further observed and data took 10 times in 10 minutes, or 1 time in every minute.

### B. THE DIAGRAM BLOCK

In this research, the diagram block is shown in [FIGURE 1](#). Setting the flow rate was done to determine the rate of droplets per minute that will be used. Droplets were detected by the Photodiode-Infrared sensor then compared by a comparator and monostable circuit as oscillator developer where the output was connected to a digital Arduino, analog data were converted to digital and then converted to drops in one minute which will be converted in ml units. The microcontroller will provide input for the motor driver to drive the stepper and peristaltic motors according to the speed settings that have

been adjusted to the flow rate settings. The microcontroller converts the droplets to flowrate. After that, the drops per minute were converted again to the infusion volume. The data processed by the microcontroller was then sent to the computer unit by the HC-11 wireless module in the form of serial communication. The data display on the computer is in the form of numerical values and graphs, which were then stored with the storage features available in the program. [FIGURE 1](#) is a diagram block of infusion pump with infrared photodiode sensor.

### C. THE FLOWCHART

[FIGURE 2](#) is a flowchart of the infusion pump using infrared photodiode sensor. The Arduino program was built based on a flowchart as shown in [FIGURE 2](#). When the device is turned on, an initialization process occurs on the LCD, then the flow rate is selected as needed, namely 30 ml/hour, 60 ml/hour, or 100ml/hour. When start button is pressed, the motor driver will run according to the predetermined speed setting. When the motor starts to move, the drop sensor activates and takes a drop reading. The microcontroller system will convert the number of drops that come out into the flow rate and volume. The data processed by the microcontroller is further sent to the computer from the transmitter to the receiver in the form of serial communication data. The receiver module circuit receives serial data that has been sent by the transmitter circuit resulting from data conversion on the microcontroller module, then the flow rate reading results will be displayed on the computer in the form of a graphic display. An important part of the development of this tool is the analog circuit. This circuit is used to amplify the measurement results so that the microcontroller system can be read.

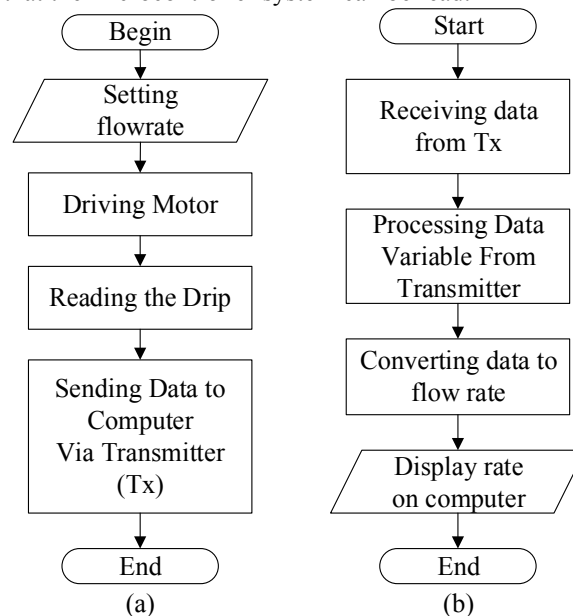

**FIGURE 2.** (a) starts from setting the drip rate according to the patient's needs, motor driver will drive peristaltic, drip rate will be read and sent to the computer. (b) Data are received and converted to flowrate and displayed on the computer

The photodiode-infrared circuit was used as a droplet detection sensor. The infrared component functions as a transmitter, emitting infrared waves that will be received by the photodiode. The output of the drip sensor circuit will be forwarded to the comparator circuit. A set of comparators was also used to compare two values and then give a result, to present which is smaller and greater. The comparator circuit on the Op-Amp will compare the input voltage on one input line with the voltage on the other input line is called the reference voltage. The monostable circuit is one of the developments of a relaxation type oscillator with a trigger. The monostable circuit does not change until a pulse comes to the input line of the oscillator. This monostable circuit is connected to the comparator output, this circuit uses IC NE555 and there is a multiturm R5 (100 K) to adjust the voltage in the monostable circuit so that the output matches the desired voltage and can detect droplets in the infrared photodiode sensor. The output of this monostable circuit is connected to the Arduino digital pin. The main concept of a monostable circuit is to use the charging and discharging of the capacitor as the delay time, it can be calculated through:

$$T_d = 1.1 RC \quad (1)$$

where  $T_d$  is Time delay (seconds),  $R$  is Resistor Circuit (Ohm) and  $C$  is Capacitor Circuit (Farad)

The stepper motor driver circuit was used to activate the stepper motor. The speed of the stepper motor is regulated by changing the delay, where the faster the delay logic changes, the faster the stepper motor rotation or vice versa.

### III. RESULTS

The design of the Infusion Module with Photodiode-Infrared Sensor can be seen in **FIGURE 3**. The photodiode - infrared, comparator and monostable circuit used in this study has worked to detect droplets in the infusion pump. The photodiode-infrared drop sensor uses the principle of transmitter (photodiode) and receiver (infrared). Photodiode will flow a current that forms a linear function of the intensity of the light received. When the infrared light received by the phototransistor is small, the output terminal of the module will give a HIGH value. Meanwhile, if the light received by the phototransistor is large, the module will give a LOW output (the led indicator will light up). The LCD display is used as a viewer of the drop sensor reading data including TPM, flowrate, and volume.

The analog circuit of infrared photodiode drip sensors, comparator circuits and monostable used in this study has worked to detect droplets in infusions. The principle of the infrared sensor circuit is that the shorter the wavelength emitted, the farther the range, while the photodiode is used as a light detection. The motor driver module was used as a drive on stepper motors and speed regulators on motors. The HC-11 wireless module was used to send and receive data on the infusion module so that the data can be displayed on the display computer.

In making the module display using this Delphi application as shown as **FIGURE 4**, programming includes a graph display program, a volume reading display program, a flow rate

reading, and drop rate (drop per minute) reading display program, as well as a flow rate value data storage program in excel and flow rate graph data in the format picture.

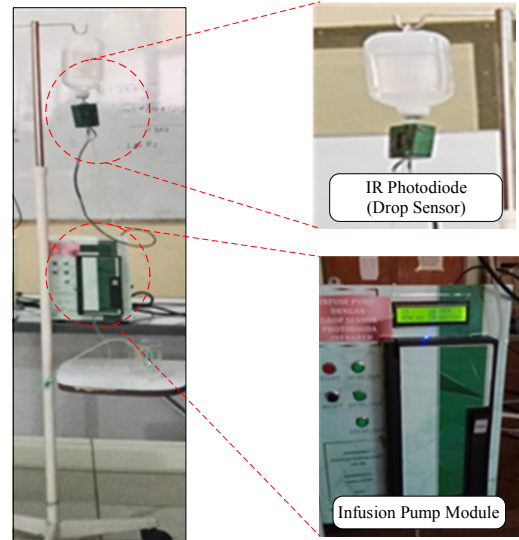

**FIGURE 3.** An Infusion Module with Photodiode-Infrared Sensor design. An infusion fluid that will be given to the patient, is paired with an infrared sensor. Then the infusion set is connected and attached to the infusion pump. The infusion pump will set the required flowrate and the flowrate will be monitored via a computer.

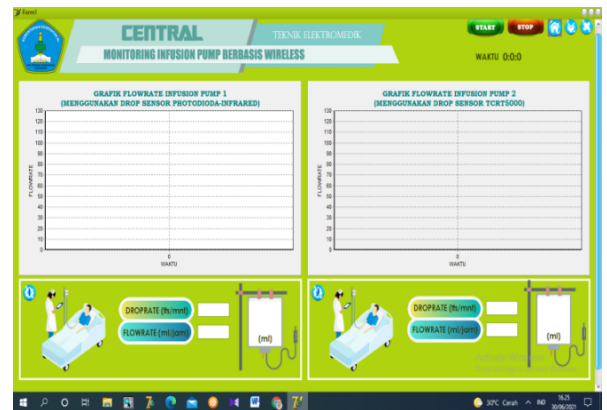

**FIGURE 4.** Display programs or applications using Delphi software on a computer. On the computer display in the form of a graph, which will help to monitor the stability of the flowrate

The following are the results of flowrate measurements on pump infusion modules with infrared photodiode sensors that are read on the LCD proposed design (**TABLE 1**):

**TABEL 1**  
**Flowrate Data Analysis with Infrared Photodiode Sensor**

Flowrate Setting (ml/hour)	% Error	Standard Deviation	Uncertainty
30	3	1.45	0.46
60	2.5	1.58	0.5
100	2.8	2.54	0.8



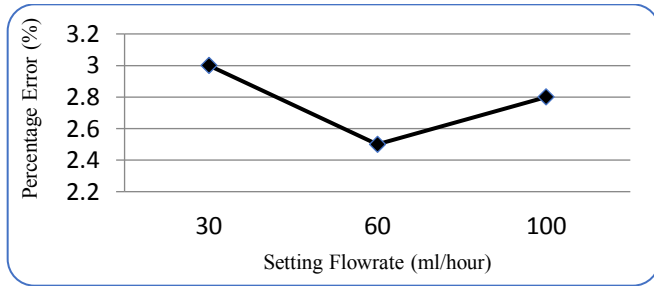

FIGURE 4. The error of flowrate measurement for infusion pump design. Smallest flowrate error is at 60 ml/hour

FIGURE 4 is a graph of the error value of module flowrate measurement errors with infrared photodiode sensors. The data in Table I are flowrate readings that are read on the LCD display using the specification of infusion set 20 drop/ml Terumo brand. Based on the results obtained, the largest error value at the setting of 30 ml/hour is 3%, while the smallest error is found at the setting of 60 ml/hour is 2.5%. The following are the flowrate measurements in the infusion pump module with infrared photodiode sensors that read on IDA (TABLE 2).

TABEL 2

Analysis of flow rate data of pump infusion module using Infrared Photodiode sensor using IDA comparison tool. The error of the module is the largest at a flowrate of 60 ml/hour. Overall, the uncertainty in the module is great

Flowrate Setting (ml/hour)	% Error	Standard Deviation	Uncertainty
30	1.2	0.11	0.03
60	2.4	0.083	0.026
100	0.8	0.11	0.035

FIGURE 5 is a graph of the error value module flowrate measurement between the design and IDA. In Table II, the lowest error values are occupied by a setting of 100 ml/hour with a value of 0.8%, while the setting of 60ml/hour and 30 ml/hour have the error value 1.2 and 2.4 %. The difference in error value between the module reading and the measurement in the IDA can be due to the lack of precision of the sensor used in setting readings or errors in data retrieval. The following are the results of wireless range testing on infusion pumps using Infrared Photodiode sensors.

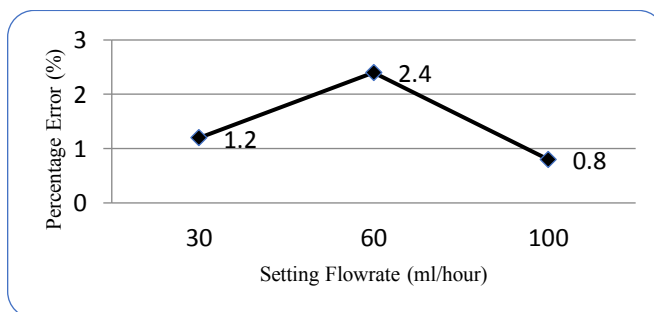

FIGURE 5. The error of flowrate measurement between the design and IDA. The error is highest at a flow rate of 60 ml/hour

TABLE 3

Seamless Wireless Range. In the data transmission trial, at a distance of 1 to 16 meters, the drop rate data transmission was successfully sent. However, there is unstable from a distance of 17-19 meters and at a distance of 21-22 meters the data is not sent

Distance Tx and Rx (meters)	Information	Percentage of overall (%)
1 -16	Sent	72.72727273
17-19	Unstable	13.63636364
21 - 22	Not Sent	13.63636364

TABLE 4

Wireless Coverage with Obstacle. In the data transmission trial, at a distance of 1 to 13 meters, the drop rate data transmission was successfully sent. However, it becomes unstable at the distance of 14-15 meters and at a distance of 16 -19 meters the data is not sent.

Distance Tx and Rx (meters)	Information	Percentage of overall (%)
1 - 13	Sent	68.42105263
14-15	Unstable	10.52631579
16-19	Not sent	21.05263158

Based on TABLE 3 and TABLE 4, wireless range without obstacles maximum distance of data can be sent a distance of 16 meters. Above that distance the delivery is unstable and when the distance above 20 meters of data is no longer accepted by transmitter. Whereas when given obstacles in the form of walls with data barriers, data can still be sent well up to a distance of 13 meters. At a distance of 14 meters, delivery has started to be unstable and the distance above 16 meters is no longer able to receive data from the transmitter

#### IV. DISCUSSION

Computer-based wireless emerging central peristaltic infusion pump monitoring, by placing an infrared photodiode drop sensor module in a dark box, was examined and tested in this study. The motorcyclist succeeded in driving the stepper and peristaltic motors according to the speed settings that had been adjusted to the flow speed settings (30, 60 and 100 ml/hour). Based on flow rate measurements using the Infuse Device Analyzer (IDA 4 Plus, Fluke, USA), the infusion pump that uses an infrared photodiode as a drop sensor has an error value of 4% at 30 ml/hour and 60 ml/hour settings, and 0.8% value error on setting 100 ml/hour. The measurement results also show the greatest uncertainty of 0.8 ml/hour, meaning that this system can be considered precise. By comparing the error value of the infusion pump using the photodiode infrared drop sensor, the error value is 5.97% at the 30 ml/hour setting, 1.13% at the 60 ml/hour setting, and 2.48% at the 90 ml/hour setting. In the research that has been done, it can be compared that the infusion pump using the TCRT 5000 drop sensor shows different error values, namely

2.2% error value at 30 ml/hour setting, 1.15% at 60 ml/hour setting and 0.58% at the 100 ml/hour setting.

Practically, a wireless lead-based Computer-based central infusion monitor appears to facilitate the nurse's task in monitoring the infusion dose given to patients at the nurse station, so as to minimize the possibility of nurse negligence. However, the data transmission range is good only within the distance of 16 meters, while when there is an obstacle, it can only transmit at a distance of 13 meters. Infusion pumps are perceived by nurses to enhance safe nursing practice. However, there were no further developments in volume parameters such as warning alarms that the infusion fluid would run out, the presence of bubbles and occlusion. Thus when the occlusion alarm is activated, the patient does not receive or greatly reduces the infusion therapy. This study has some shortcomings, namely the test is still limited to 3 droplet rate settings, has not tried various sensor positions. However, in general, the results of this study can be implemented to patients who are being treated using an infusion pump.

## V. CONCLUSION

Based on the purpose of this study, it can be concluded that the accuracy of the fall sensor in monitoring the central peristaltic infusion using a photodiode infrared drop sensor has been analyzed. From the test and measurement, the error value is quite good, in which it does not exceed the calibration tolerance limit. The ATMEGA328 microcontroller module combined with several other electronic components and combined with stepper motor and peristaltic mechanics is able to work well in running the infusion pump system. Based on the measurement results, the flowrate reading module setting value of 30 ml/hour has the highest error value of 3%, while based on IDA readings the smallest flowrate value at setting 100 ml/hour has an error value of 0.8%. For the next step, it can be tested with more variations in the drop rate so that the level of accuracy will be known. In this case, some suggestions that can be considered for further refinement is by adding parameters and settings, designing or using more sensitive sensors, using several brands and types of infusion set sizes, increasing the accuracy of the tool to avoid many errors, and adding antennas to the wireless system to achieve long distances which is quite far.

## VI. REFERENCES

- [1] M. Nunnally, C. P. Nemeth, V. Brunetti, and R. I. Cook, "Lost in menospace: User interactions with complex medical devices," *IEEE Trans. Syst. Man, Cybern. Part A Systems Humans.*, vol. 34, no. 6, pp. 736–742, 2004.
- [2] E. A. Skryabina and T. S. Dunn, "Disposable infusion pumps," *Am. J. Heal. Pharm.*, vol. 63, no. 13, pp. 1260–1268, 2006.
- [3] E. T. Pierce, V. Kumar, H. Zheng, and R. A. Peterfreund, "Medication and volume delivery by gravity-driven micro-drip intravenous infusion: Potential variations during 'wide-open' flow," *Anesth. Analg.*, vol. 116, no. 3, pp. 614–618, 2013.
- [4] E. Abu-Haydar *et al.*, "User-centered design: Developing the reliable delivery system – a low-cost, non-electric, pneumatic infusion pump," *Med. Devices Evid. Res.*, vol. 14, pp. 185–192, 2021.
- [5] N. Stagers, D. Kobus, and C. Brown, "Nurses' evaluations of a novel design for an electronic medication administration record," *CIN - Comput. Informatics Nurs.*, vol. 25, no. 2, pp. 67–75, 2007.
- [6] C. Bertagnolli, "Delle vicende dell'agricoltura in Italia; studio e note di C. Bertagnolli.," *Delle vicende dell'agricoltura Ital. Stud. e note di C. Bertagnolli.*, vol. 13, no. 3, pp. 319–340, 2011.
- [7] J. I. Westbrook, M. I. Rob, A. Woods, and D. Parry, "Errors in the administration of intravenous medications in hospital and the role of correct procedures and nurse experience," *BMJ Qual. Saf.*, vol. 20, no. 12, pp. 1027–1034, 2011.
- [8] P. Y. Han, I. D. Coombes, and B. Green, "Factors predictive of intravenous fluid administration errors in Australian surgical care wards," *Qual. Saf. Heal. Care*, vol. 14, no. 3, pp. 179–184, 2005.
- [9] V. Wirtz, N. D. Barber, and K. taxis, "An observational study of intravenous medication errors in the United Kingdom and in Germany," *Pharm. World Sci.*, vol. 25, no. 3, pp. 104–111, 2003.
- [10] D. H. Cousins, B. Sabatier, D. Begue, C. Schmitt, and T. Hoppe-Tichy, "Medication errors in intravenous drug preparation and administration: A multicentre audit in the UK, Germany and France," *Qual. Saf. Heal. Care*, vol. 14, no. 3, pp. 190–195, 2005.
- [11] K. Wright, "Do calculation errors by nurses cause medication errors in clinical practice? A literature review," *Nurse Educ. Today*, vol. 30, no. 1, pp. 85–97, 2010.
- [12] L. L. Leape *et al.*, "Systems Analysis of Adverse Drug Events," *JAMA J. Am. Med. Assoc.*, vol. 274, no. 1, pp. 35–43, 1995.
- [13] K. K. Giuliano and C. Niemi, "The urgent need for innovation in I.V. Smart pumps," *Nurs. Manage.*, vol. 46, no. 3, pp. 17–19, 2015.
- [14] M. Husch *et al.*, "Insights from the sharp end of intravenous medication errors: Implications for infusion pump technology," *Qual. Saf. Heal. Care*, vol. 14, no. 2, pp. 80–86, 2005.
- [15] U.S. Department of Health and Human Services, "Enforcement Policy for Gowns, Other Apparel, and Gloves During the Coronavirus Disease (COVID-19) Public Health Emergency: Guidance for Industry and Food and Drug Administration Staff," *Cent. Devices Radiol. Heal.*, vol. 2019, no. March, 2020.
- [16] M. Taylor and R. Jones, "Risk of Medication Errors With Infusion Pumps," *Patient Saf.*, no. December, pp. 61–69, 2019.
- [17] J. W. C. Blake, K. K. Giuliano, R. D. Butterfield, T. Vanderveen, and N. M. Sims, "Extending tubing to place intravenous smart pumps outside of patient rooms during COVID-19: An innovation that increases medication dead volume and risk to patients," *BMJ Innov.*, vol. 7, no. 2, pp. 379–386, 2021.
- [18] P. Carayon, A. S. Hundt, and T. B. Wetterneck, "Nurses' acceptance of Smart IV pump technology," *Int. J. Med. Inform.*, vol. 79, no. 6, pp. 401–411, 2010.
- [19] P. Rangsee, P. Suebsombut, and P. Boonyanant, "Low-cost saline droplet measurement system using for common patient room in rural public hospital," *JICTEE 2014 - 4th Jt. Int. Conf. Inf. Commun. Technol. Electron. Electr. Eng.*, 2014.
- [20] K. K. Thariyan, S. Verma, S. R. Taneja, R. C. Gupta, and S. S. Ahluwalia, "Design and development of a unique drop sensing unit for infusion pump," *J. Sci. Ind. Res. (India)*, vol. 61, no. 10, pp. 798–801, 2002.
- [21] H. Firdaus, B. G. Irianto, Sumber, and J. Lu, "Analysis of the Drop Sensors Accuracy in Central Peristaltic Infusion Monitoring Displayed on PC Based Wireless (TCRT5000 Drop Sensor)," *J. Electron. Electromed. Eng. Med. Informatics*, vol. 4, no. 1, pp. 42–49, 2022.
- [22] K. K. Giuliano, "IV Smart Pumps: The Impact of a Simplified User Interface on Clinical Use," *Biomed. Instrum. Technol.*, pp. 13–21, 2015.
- [23] S. Zheng, Z. Li, and B. Li, "The design of liquid drip speed monitoring device system based on MCU," *AIP Conf. Proc.*, vol. 1864, no. August, 2017.
- [24] D. Qiliang, L. Jianhao, and T. Lianfang, "Simulation and Design of Intravenous Infusion Dripping Rate Detection based on Infrared Ray," *Proc. 3rd Int. Conf. Multimed. Technol.*, vol. 84, no. Iv, pp. 918–925, 2013.

- [25] S. Hossain, S. Sharmin, T. Faruk, and M. K. Islam, "Low-Cost Digitization of Infusion Pump for Real-time Automated Flow Rate Monitoring and Warning," *ICIET 2019 - 2nd Int. Conf. Innov. Eng. Technol.*, pp. 23–24, 2019.