

Measuring Respiration Rate Based on Android

Shofiyah, I Dewa Gede Hari Wisana, Triwiyanto Triwiyanto, Sari Luthfiyah
Electromedical Engineering Department of the Ministry of Health polytechnic, Surabaya
Jl. Pucang East Jajar No. 10, Surabaya, 60245, Indonesia
Shofiyah288@gmail.com, hariwisana88@gmail.com, triwiyanto123@gmail.com,

Abstract-Respiratory rate is the total number of breath or breathing cycle, which occurs every minute. Abnormal respiratory rate is a sensitive indicator for danger patients requiring medical treatment immediately. The objective of the study is to design a respiration rate monitor via an Android mobile phone. In this study, we used flex sensors to detect the respiration rate. The flex sensors were placed in the human stomach diaphragm which detects the changes in the human stomach diaphragm during breathing. The measurement results are displayed on the liquid crystal display (LCD) 2 x 16. The data will be sent via a Bluetooth connection to the android to display the values and graphs. The comparison between the design and standard showed that the maximum error is 4.69% while the minimum error is 1.52%. The average error for all measurement is 2.83%. It can be concluded that the tool wear is eligible because it is still below the minimum threshold of 10% error.

Keywords - Respiration rate; Android; Arduino microcontroller; Bluetooth

I. INTRODUCTION

Respiratory rate is the total number of breath, or breathing cycle, which occurs every minute. Abnormal respiratory rate, such as respiratory rate that is too high (tachypnea), too low (bradypnea), or even halted some time (apnea), is a sensitive indicator for patients who require treatment physiological health immediately. The simplest method for determining the rate of breathing is to calculate directly (manually) moving up and down the chest wall or to hear the sound of the breath (breathing sounds) through a stethoscope. This method is highly dependent on the concentration of the mind and senses actors sensitivity measurement and observation. Therefore human nature is easy to forget, tired and bored, so now developed a method of measurement and observation of respiratory rate electronically[1],

Sepsis is a systemic infectious disease that originated from the Systemic Inflammatory Response Syndrome (SIRS), SIRS showed systemic response of the body against various trauma experienced by the body so that people with sepsis require special treatment and quick so that no organ damage [2], The diagnosis of sepsis is made if found to be at least 2 clinical symptoms of Systemic Inflammation Response Syndrome (SIRS) such as body temperature $<36^{\circ}\text{C}$ or $>38^{\circ}\text{C}$, Speed pulse rate >90 beats / min, respiration rate >20 breaths / min or $\text{PaCO}_2 <32$ mmHg, and blood white cell count $>12,000$ / mm³ or <4000 / mm³ atau 10%[3], Standard for the diagnosis of sepsis is the discovery of bacteria in the blood coupled with clinical symptoms of multiple organ disorders.

In 2013 Archita Agnihotri conduct a study entitled "The Human Body Respiratory Measurement Using Digital Temperature Sensor with I2C interface". The advantages of this research are already using I2C, vital signs can be measured in a medical setting, at home, in the location of a medical emergency, or elsewhere. The weakness of this study is the measurement of the RR using the mask which can make

patients feel uncomfortable[4], In 2013 Souvik Das conducted the study with the title "Development Of A Respiration Rate Meter-A Low-Cost Design Approach". This study uses an IR-LED IR-LED transmitter and receiver. The advantage of this study is low cost and can be used at home. While weakness of this tool is the tool is made simple and still use the 7 segment display[5], Research conducted by Torib Hamzah and Resources in 2018 with the title "Design of LCD Graph Appearance Respiratory Equipment with Patient Data Storage" research using DHT humidity sensor 11 for counting the number of breaths in one minute. The advantages of this research that the sd card is used to store the results of the examination of the patient. While the weakness of this study is still using LCD graphic display[6],

Based on the identification of the above problems, the authors intend to design the tool "Measurement of Respiration Rate, Heart Rate, and Temperature Via Android (Parameters Respiration Rate)". Which can determine the value of heart rate and body temperature in patients and in case the value of belonging to the early symptoms of sepsis or SIRS called to serve as a reminder of the onset of the risk of disease Sepsis,

II. MATERIALS AND METHODS

A. Experimental Setup

Data collection was performed on 5 healthy individuals aged 20-22 years and each - each person is measured 5 times each person.

1) Materials and Tools

This study uses flex sensors ± 2.2 with 20K ohm resistance change from baseline resistance of about 25k ohms. Flex sensors placed in the abdominal area to detect when the breath changes abdominal diaphragm. Components used to use 328 as a microcontroller Atmega Differential Amplifier circuit as the conversion of resistance into voltage.

2) Experiment

In this study, researchers conducted measurements of the output of the differential circuit with an oscilloscope. The author conducted measurements on a sample number of respondents by random breath with an appeal that is manual measurement tool.

B. The Block Diagram

In Figure 1 parts contained in the box broke - broke a parameter that researched by the author is Respiration Rate. Press the power switch so that the whole series to get the voltage of the battery. Flex sensors will detect the movement of the patient's abdomen during breathing, then the output is routed to the analog signal conditioner. The output of the analog signal conditioning will be forwarded and managed by ATmega328 into data Respiration Rate. Data Respiration Rate, and will be displayed on a 2x16 character LCD and 05 HC-transmitted using Bluetooth to mobile phones. Controlled communication via mobile phones. After the phone connects to the device, the data - the data will be managed by the application on the phone.

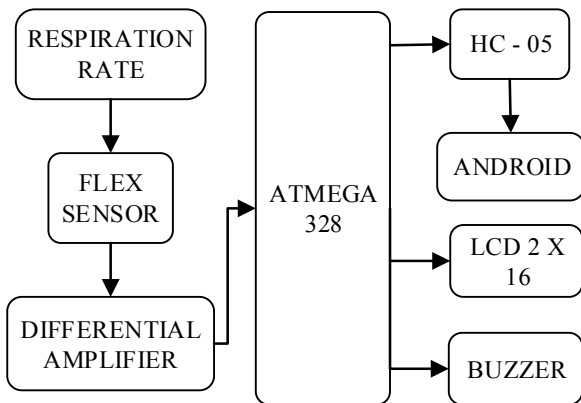

Fig. 1. Block Diagram Parameters Respiration Rate

C. The Flowchart Arduino

When the power button has pressed the tool in a state ready and will start initialization. When the sensor Respiration Rate, has been attached to the body part that has been desired, the start button is pressed. Then the sensor will start reading and processed on the ATmega328, then the result of the processing will be sent via Bluetooth in numbers to android. When the value of any two or all three of these three parameters show the value of the symptoms of sepsis or SIRS then the buzzer on the tool will beep to alert,

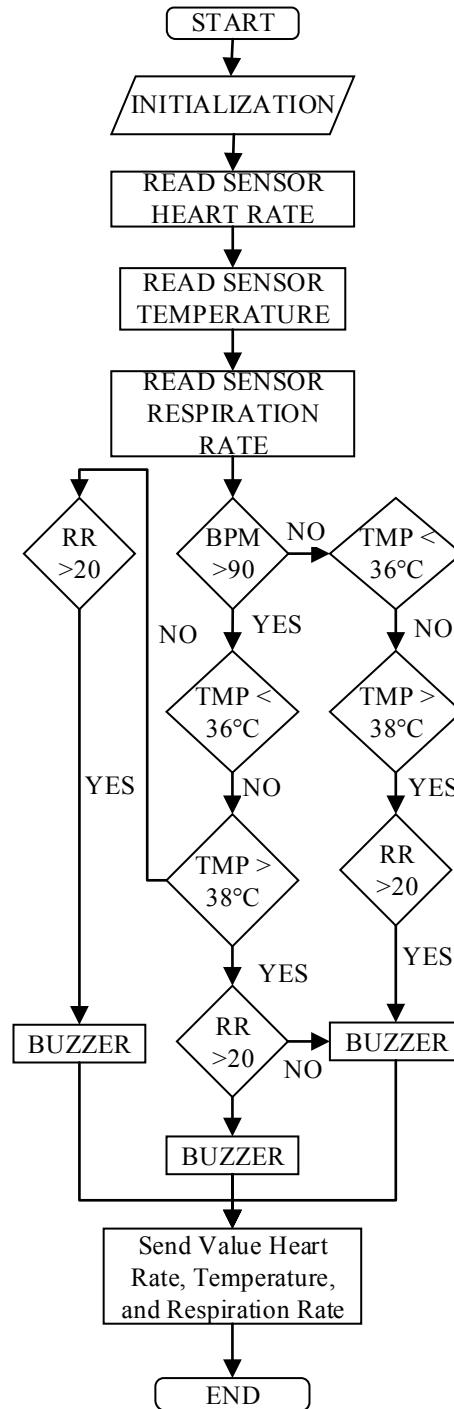

Fig. 2. The flowchart of the Arduino Program

D. The flow chart of Android

When android in an active state will begin to initialize. Setting the monitoring time. After that, fill in the name and age of the patient, then the Bluetooth connection configuration. If it had been the result data value Respiration Rate and will be displayed on the screen of android. When the value of data of any two or all three of these three parameters shows the value

of the symptoms of sepsis or SIRS then the android screen will display a warning in writing.

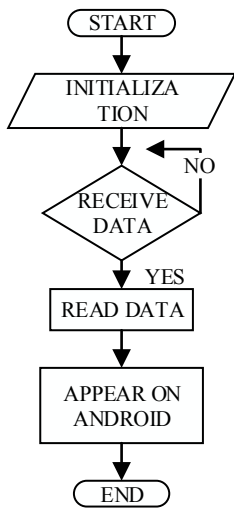

Fig. 3. Flow Chart Android

E. The Analog Circuit

The use of flex sensors for bending author readings using signal conditioning circuit such as a voltage divider. Voltage divider circuit serves to convert sensor flex resistance change into a voltage change. From then as the input voltage division Differential Amplifier circuit V1, V2 input derived from the division amid the multitur. The differential of output circuit into the filter circuit LPF so that the resulting signal is not noise.

1) Different Amplifier

Supply Voltage 5 VDC for supply Ic lm358 and sensor flex. using differential amplifier circuit. Voltage V1 obtained from the division of the flex sensors and a 47k resistor as a ground. Entered at number 2 IC LM358 foot. The voltage V2 obtained from multitur. The voltage input on foot No. 3 IC LM358. Rf differential circuit using a resistor 1M. And Rground of 330K

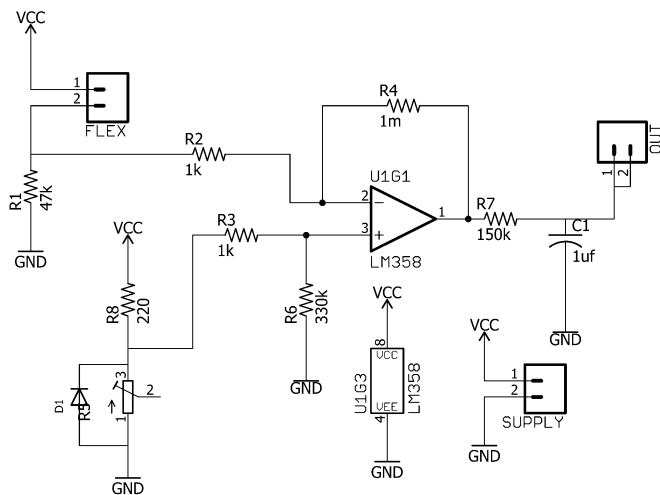

Fig. 4. Differential Amplifier

2) Bluetooth Module

Bluetooth connector serves to connect the TX RX of microcontroller with RX and TX Bluetooth HC-05. Input connector serves to connect the sensor output to pin analaga and minimum digital circuit system.

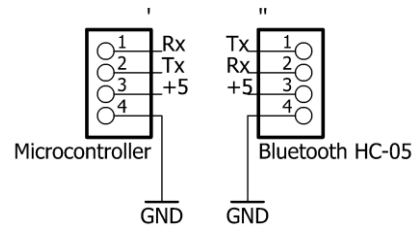

Fig. 5. Bluetooth Connection

3) The series MinimumSystem

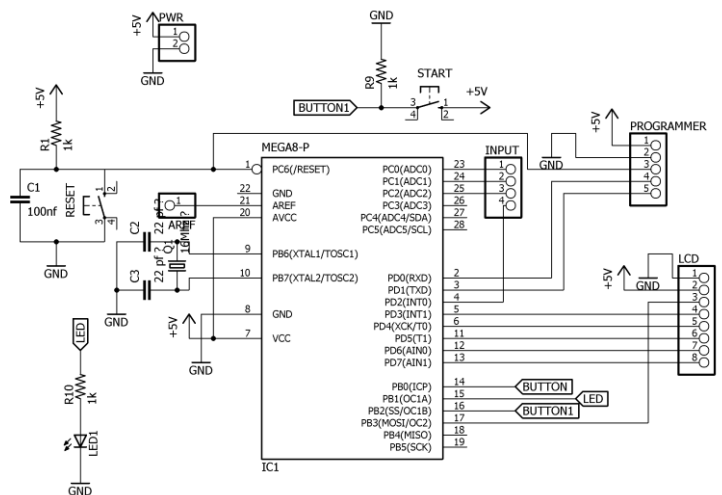

Fig. 6. Minimum System Circuit

Terserbut circuit requires ATmega328 as a regulator of the system where there is a 16.000 MHz crystal that serves as an external clock for the functioning of the microcontroller. Reset button to restart the microcontroller work. The start button to start the main program. There is an LCD connector that serves to connect the LCD 2 x 16 to the minimum range of the system. Connector serves to inject programmers from arduino software program to the microcontroller.

III. RESULTS

Fig. 6 is series of respiration rate. Design of a diffrent amplifier and flex sensors.

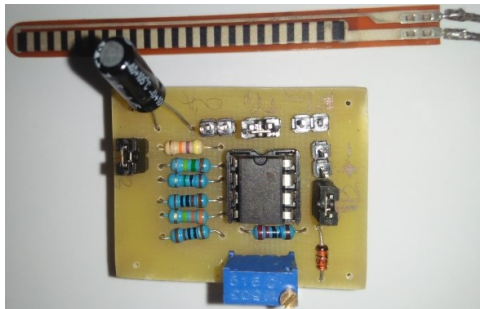

Fig. 7. The series of Respiration Rate

Fig. 8 Design of minimum system and module Bluetooth HC-05 board.

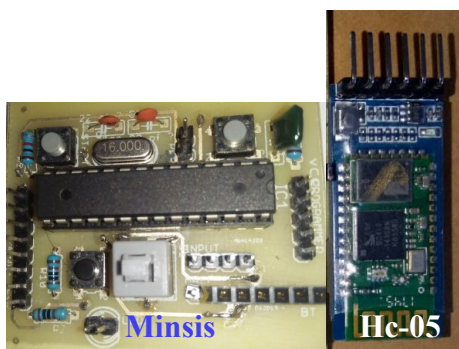

Fig. 8. The digital part of the design Respiration Rate

1) The Respiration Rate Design

The results of the flex sensor output voltage division are used as input V1 Differential Amplifier circuit at the foot of the LM358 IC number 2, while the input voltage V2 are entered on foot IC LM358 resulted from sharing voltage on multiturun. The output of the differential amplifier circuit will be entered on foot A1 on Atmega 328 untuk processed into digital data, which will be displayed on the LCD 2x16 characters and Android using Bluetooth connection.

2) The Listing Program for Arduino Respiration Rate

The output signals from the Differential Amplifier will be managed through Atmeg328 with the following programs:

```
flex = analogRead (A1);
Serial.print (flex);
Serial.print (",");
Serial.println (hold1);
if (ref1 <= flex) {ref1 = flex;}
else
{
ref1 = ref1;
hold1 = (ref1 * 9/10);
```

```
if ((flex <= hold1) && (mark == 0))
{
count ++;
if (count == 100)
{Count = 0; mark = 1;}
}
if ((flex <= hold1) && (mark == 1)) {
ref1 = 100;
mark = 0;
hold = 60;
}
waktuRR = millis () - waktusekarangRR;
if (waktuRR <60000)
{
if (flex> hold1)
{
count = 0;
beat = 1;
}
if (flex <hold1) {
if (beat == 1)
{
if (waktumonostabil> delayMonostabil) {
detak1 ++;
nafasmanual ++;
waktumonostabil = 0;
}
}
beat = 0;
}
}
else
{
respiration = detak1;
waktusekarangRR = millis ();
detak1 = 0;
}
if (waktumonostabil <60000) {waktumonostabil =
waktumonostabil + 6;}
```

3) Listing program SIRS

Early Detection Program Listing Requirements sepsis symptoms when 2 or 3 of the conditions are met.

```
if (36 <TEMPERATURE <38) {
kondisisuhu = 1;
}
else {
kondisisuhu = 0;
}
if (BPM> 90) {
kondisiBPM = 1;
} Else {
```

```

kondisiBPM = 0;
}
if (RPM > 20) {
kondisiRR = 1;
} Else {
kondisiRR = 0;}
if (kondisiSuhu + kondisiBPM + kondisiRR >= 2)
    
```

```

{
int GejalaTerdeteksi;
digitalWrite (Buzzer, HIGH);
delay (300);
digitalWrite (Buzzer, LOW);
delay (1000);
}
    
```

4) Listing Program Delivery Bluetooth into Android.

Used to transmit data Serial.print function () / transmit data at pin Tx / Rx PD1 microcontroller to the Bluetooth and to receive data using Serial.read () / receive data from Bluetooth Tx pin to the Rx / PD0 microcontroller. The data is sent to the receiver using a marker at the beginning, middle, and end of the transmitted data in order to facilitate the scanning data from the sender.

```

Void setup () {
Serial.begin (9600);}
Void loop () {
Serial.print ( "Input |");
Serial.print ( abs (BPM));
Serial.print ( "|");
Serial.print ( int (suhu.getTempCByIndex (0) * 100));
Serial.print ( "|");
Serial.print ( detak1);
Serial.println ( "|");
 kirimkeAndroid = 0; }
    
```

5) Program At MIT APP

a) Block Connections Bluetooth module with Android Apps

Fig. 9. Bluetooth Election Program

b) Bluetooth Connection Program

Once we choose a name and Bluetooth address, Bluetooth module will be connected with the android. When the Bluetooth module are connected with android applications, text that reads not connected will turn out to be connected and will change color from red to green. If the Bluetooth connection with android application is lost then the text will re-read not connected and red.

Fig. 10. Bluetooth Connection Program

c) Program Data Receive RR On Android

text the RR will contain data from the index data on the global list 4 which means 3 to the list will be read as the value of respiration.

Fig. 11. Program Data Receive RR

d) Terms Deteksi Awal Program Symptoms Sepsis

On the block, according to the diagnosis of sepsis is made if found to be at least 2 clinical symptoms of Systemic Inflammation Response Syndrome (SIRS) such as body temperature 36°C or 38°C, Speed pulse rate > 90 beats / min, respiration rate > 20 breaths / min. Then every two out of three, or maybe a third of the clinical symptoms appear then the android application will display a warning in the form of text Danger of red and red color on text change parameter values from two or three parameters that show symptoms. Once these symptoms had not appeared then the value of the parameter text will turn black as before and text Danger will be lost.

Fig. 12. Symptoms Early Detection Program Terms Sepsis

e) RR Graph Plotting Program

Both block above (Figure 5.9) is a program of plotting data from RR. In the data plotting RR using dots and dashes that RR values that appear to form a graph in the form of lines and dots. Plotting is done once every 15 seconds for one minute so that the data in plotting amounted to 4 data. Y value obtained from the RR value in reading, to the value of X obtained from multiples of 15 seconds so that the data will form the pattern coordinates (X1, Y); (X2, Y); (X3, Y); (X4, Y);

Fig. 13. RR graph plotting program

f) Graph Plotting Program Update Every 1 Minute

In the block (fig. 13) is a program that serves to restart plotting the graph if it reaches Waku 1 minute. When plotting the graph has reached 1 minute then each canvas will remove

data that emerged during the first minute and restart value on the X-axis and Y to 0.

Fig. 14. Graph plotting Program Update Every 1 Minute

6) Output From Circuit Differential Amplifier Input Current

Fig 14. is the result of the output from the differential amplifier circuit to a prior given input or flex sensor 2.2 is not installed in the patient's stomach. Interference signals generated was very small at 200mV.

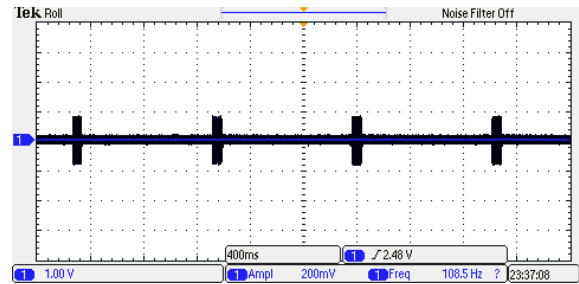

Fig. 15. Output From circuit Differential Amplifier Input Current

Fig 15 is measurement image on the feet of Differential Amplifier output after the input of the flex sensors that have been installed on the stomach of the patient and the patient breathes so that the sensor flex flexed. The measured amplitude value is 1.04 volts. There is an increase of 0.84 Volt. The increase is due to the change of resistance in the sensor resulting in a change in the voltage division of the input voltage V1. Each patient has a different voltage change varies depending on the bending of the flex sensor.

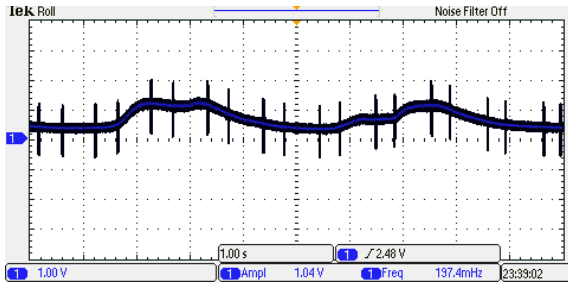

Fig. 16. Output Differential Amplifier Circuit

7) The Error of RPM (Respiration Per Minutes) value

The results of data collection can be on the show as follows:

TABLE I. RESULTS OF MEASUREMENT ERROR PARAMETER VALUE RESPIRATION WITH STANDARD EQUIPMENT

Respondents	Error (%)
R1	1.69
R2	1.52
R3	1.64
R4	4.65
R5	4.69
Avarage	2,83

From the data attribute Table 4.1 Average value ratio - measuring average, standard deviation value, the value of uncertainty, and the error value of the parameter respiration. It is seen that the error value generated module is very small with a maximum error value is 4.69%. It is still on the threshold of maximum permitted error.

Here is a comparison chart between the modules and manuals.

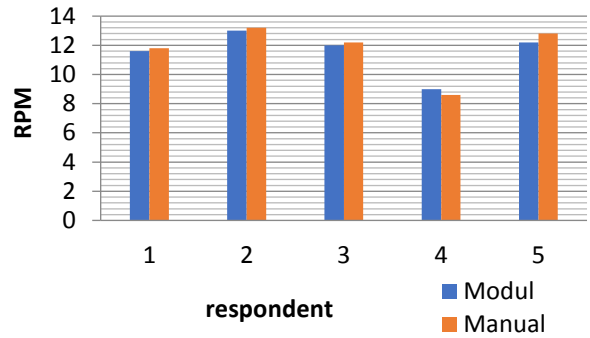

Fig. 17. The comparison of RR Between design and standart

IV. DISCUSSION

The comparison between the measuring instrument with a manual has the error with a high of 4.69% on the respondents to 5, while the second respondent has the lowest error value of 1.52. The average error on the 5th of data amounts to 2.83%. It can be concluded that the tool wear is eligible because it is still below the minimum threshold of error of 10%[7]

V. CONCLUSION

Circuits and sensors can work in accordance with its function. On android apps are made to work well for displaying the data received from the instrument and also the Arduino program created goes according to plan.

REFERENCES

- [1] W. E. Sonata and Wildian, "Rancang Bangun Alat Pengukur Suhu Tubuh Dengan Tampilan Digital dan Keluaran Suara Berbasis Mikrokontroler AVR AT MEGA 8535," J. Fis. Unand, vol. 4, no. 4, pp. 32-43, 2015.
- [2] R. A. Rano K. Sinuray, Dika P. Destiani, "Cost of Illness dan Cost Containment Analysis Penggunaan Antibiotik Empirik Kombinasi pada Pasien Sepsis di Bandung," vol. 1, pp. 127-135, 2012.
- [3] T. Brown, A. Ghelani-Allen, D. Yeung, and H. B. Nguyen, "Comparative effectiveness of physician diagnosis and guideline definitions in identifying sepsis patients in the emergency department," J. Crit. Care, vol. 30, no. 1, pp. 71-77, 2015.
- [4] A. Agnihotri, "Human Body Respiration Measurement Using Digital Temperature Sensor with I2c Interface," Int. J. Sci. Res. Publ., vol. 3, no. 3, pp. 1-8, 2013.
- [5] S. Das, "Development of A Respiration Rate Meter - A Low-Cost Design Approach," Heal. Informatics - An Int. J., vol. 2, no. 2, pp. 9-16, 2013.
- [6] A. Key, T. Sch, J. E. Tech, and T. Hamzah, "Scholars Journal of Engineering and Technology (SJET) Design of LCD Graph Appearance Respiratory Equipment with Patient Data Storage," pp. 282-287.
- [7] Permenkes Departemen Kesehatan RI, "Pedoman Pengujian dan Kalibrasi Alat Kesehatan," pp. 1-98, 2001. Jakarta