

RESEARCH ARTICLE

OPEN ACCESS

Manuscript received December 31, 2021; revised February 6, 2022; accepted February 13, 2022; date of publication May 10, 2022

Digital Object Identifier (DOI): <https://doi.org/10.35882/ijeemi.v4i2.7>

This work is an open-access article and licensed under a Creative Commons Attribution-ShareAlike 4.0 International License ([CC BY-SA 4.0](https://creativecommons.org/licenses/by-sa/4.0/))



Design Body Mass Index (BMI) and Body Fat Percentage Using Fuzzy Logic

Irmalia Suryani Faradisa¹, Radimas Putra Muhammad¹, and Dyah Ayu Girindraswari³

¹Electrical Engineering Department, National Institute of Technology, Malang, Indonesia

Corresponding author: Irmalia Suryani Faradisa (e-mail: irmalia_suryani_faradisa@lecturer.itn.ac.id).

This work was supported in part by the National Institute of Technology, Malang.

ABSTRACT Nutritional status is something that should consider because it is related to the level of health. Poor health can lead to malnutrition and death. The purpose of this study is to create a device with a system that can determine the value and category of Body Mass Index (BMI) automatically using fuzzy logic to maintain nutritional status. However, because BMI can only decide underweight or overweight, it is necessary to determine the fat percentage based on the British Journal of Nutrition. In determining BMI and fat percentage, a load cell weight sensor with a capacity of 200 kg as a bodyweight measurement, an ultrasonic sensor HCSR-04 as a body height measurement, and a keypad that functions to enter a name, age, gender, and type of activity data. Database in this system can provide and store easier and real-time data, so the data output is accessible directly. The results are analyzed by comparing the measurement with standard device. The BMI test taken 5 times, showed that the categories in the system (very thin, thin, normal, heavy, obese) were the same as the MATLAB test and manual calculations. Meanwhile, the results of testing body fat percentage taken 4 times also show the same category as the Body Monitor device. So, this system can use for daily to monitor the condition of nutritional status and fat percentage in real-time.

INDEX TERMS Body Mass Index, Body Fat Percentage, Fuzzy Logic, Database.

I. INTRODUCTION

In determining a person's nutritional status, it can be done anytime in a simple way, namely by measuring Body Mass Index (BMI) [1]. Nutritional status is one of the factors that affect a person's level of health [2]. If a person has poor nutritional status, it can be associated with poor health. Poor health is closely related to malnutrition and can increase the risk of infectious diseases and chronic diseases [3], such as cardiovascular problems (complications of the heart and blood vessels, hypertension, and stroke), diabetes, and cancer which are the causes of death in Indonesia [4], [5]. However, because the Body Mass Index is only a parameter in determining nutritional status (such as obesity) or as a measure of overweight, a parameter of body fat percentage is needed [3].

Fat content is a necessary part of the body that functions as a source of energy reserves that can affect a person's nutritional status [6]. One of the things that affect the level of fat in the body is gender. Fat content in women has a higher

value than fat content in men. That is because women experience twice the accumulation of fat levels from men who serve as a protective organ of the body, while men will experience muscle development [3]. Therefore, everyone needs to know the value of body fat percentage so that avoid dangerous diseases due to excess fat. Calculation percentage of fat content carry out using a predictive formula based on the British Journal of Nutrition, which uses Body Mass Index values and age as parameters [7]. Calculation of Body Mass Index as a determinant of a person's nutritional status can be done using manual calculations. If the measurement carries out by many people, then this method is less effective because it takes a long time [1]. Therefore, the determination of the Body Mass Index is using a fuzzy logic method that gives accurate results and does not take a long time [8]. Fuzzy logic is a logic with some concepts of truth sustaining membership values between 0 and 1 [9]–[11]. Fuzzy logic methods can use for determining nutritional status include the Mamdani

method, the Takagi Sugeno method, and the Tsukamoto method [10]. In this study, the Mamdani method is used as a determinant of nutritional status, whereas the Mamdani method is also known as the Min-Max method [10], [12]. The Min-Max method is a search for the minimum value in each rule which then looks for the maximum value from the combined consequences of each rule.

All measurement results are processed to determine calorie needs in 1 day and determine what foods a person can consume with a specific caloric value [13], [14]. The measurement results are displayed on the LCD and a website that can access anytime and anywhere [14], [15]. Therefore, the subject can monitor the development of nutritional status every month and every week, to produce an ideal body condition. The idealist body condition will result in a healthy body condition and avoid various chronic diseases [14].

There are several studies related to Body Mass Index, both calculations using formulas and fuzzy logic methods. In 2017, research was carried out by Dr. M. Kannan et al, with the title Mechanized Body Mass Index (BMI) Calculator Using PIC 16F877A [16]. This tool uses an ultrasonic sensor as a body height meter and a Load Cell as a bodyweight meter, which is then used to determine the Body Mass Index (BMI) and displayed on the 20X4 LCD. However, this tool only calculates the Body Mass Index based on the formula and only displays the measurement results on the 20X4 LCD. So, the datum can only be accessed and viewed once. There is also research related to the BMI, that is accuracy of Sugeno method with anthropometry on determination natural patient status in 2017 [17]. Defuzzification is the fuzzy method used in calculating nutritional status, only using the average datum calculation. The latest research in 2021, A. D. Ab Karim et al, have researched the calculation of BMI in real-time [18]. This tool manages to display and save datum in the web-based application, and give a nutritional advice. However, in this tool, the calculation of BMI still uses the formula and there is no calculation of body fat percentage. Munawar A. Riyadi et al, developed a tool for measuring the percentage of fat content using electrodes displayed on the LCD [19]. However, this tool uses weight and height data entered via a keypad. So, data from the measurement of the percentage of fat content is not real and can only be seen once because data is not stored.

Based on some of the studies above, the purpose of this research is to get the results of measuring Body Mass Index and body fat percentage accurately. Measurements of weight and height for Body Mass Index and body fat percentage are carried out directly by sensors, so, real data is obtained. Furthermore, the determination of the Body Mass Index uses the fuzzy logic of the Mamdani method which produces more detailed data, because the defuzzification section produces data close to the actual results. So, it supports the results of this tool more accurately. By utilizing Internet of Things-based technology, the display of the value of each measurement result can be seen in real-time [20].

II. MATERIAL AND METHODS

A. EXPERIMENTAL DESIGN

This research was conducted using a load cell weight sensor, which was installed between 2 acrylics with a thickness of 2.5 cm and a size of 50X50 cm. Moreover, this system uses an ultrasonic sensor mounted on a pole with a box thickness of 0.3 cm [20]. The subject must be stationary or not moving much. Collecting data on adult subjects in the age category of 22-23 years [21], and each subject measured 15 times.

1) MATERIALS AND TOOLS

The material used as a mechanical tool is acrylic. Acrylic is used to provide security to the subject [20]. The acrylic used is different in each part. It aims to adjust the capacity of the subject taking measurements.

Meanwhile, the components used in this system include a load cell weight sensor with a maximum capacity of 200 kg as a weight measurement[[22], an Ultrasonic HCSR-04 distance sensor as a height measurement [1], a 4X4 size keypad as a component for inputting datum (name, age, gender, and activity factors) [23], DC to DC step-down module, power supply, Arduino Mega 2560 as a microcontroller, 20X4 LCD as a display of measurement and calculation results [1], [23], and the NodeMCU ESP8266 module as a Wi-Fi module that sends datum to the database [24]. Fuzzy logic was introduced by Prof. Lotfi A. Zadeh in 1965, which was implemented in problems with the element of uncertainty [25]. Fuzzy logic consists of several methods, such as Mamdani, Sugeno, and Tsukamoto. In this study, the Mamdani fuzzy logic method was used which has 4 stages, specifically:

a. Fuzzification

This section consists of 2 variables, which are input and output variables [25]. The input variables consist of body weight and height, while the output variable is Body Mass Index (BMI). The two variables are represented in several fuzzy sets:

Body weight = thin, normal, and weight.

Height = short, normal, and tall.

Body Mass Index = very thin, thin, normal, weight, and obesity.

Input and output datum are mapped into membership values with an interval of 0-1. These membership functions include :

1. Ascending Linear Membership Function is indicated by the set in the domain with membership degree 0 which moves to the right towards the domain with a higher membership degree. The Ascending Linear Membership Function can be formed as a **FIGURE 1** and an equation 1 [25].

$$\begin{cases} 0; & x \leq a \\ \frac{x-a}{b-a}; & a \leq x \leq b \\ 1; & x \geq b \end{cases} \quad (1)$$

Description:

a = smallest domain when membership degree is smallest.

b = the highest degree of membership in the domain.

Membership Function

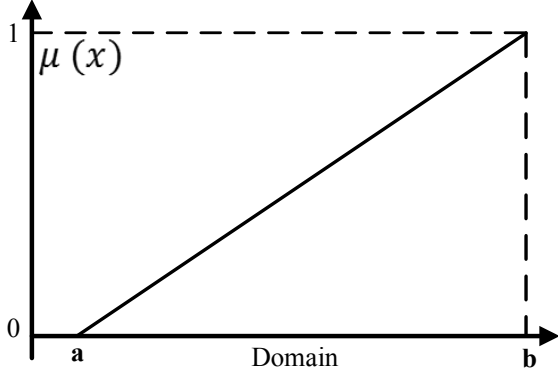

FIGURE 1. Ascending Linear Membership Function.

2. Downward Linear Membership Function is the opposite of ascending linearity, where the curve starts from the domain of the highest degree of membership to the domain of the lowest degree of membership. This is shown in the FIGURE 2 and equation 2 [25].

$$\begin{cases} 1; & x \leq a \\ \frac{b-x}{b-a}; & a \leq x \leq b \\ 0; & x \geq b \end{cases} \quad (2)$$

Description:

a = the smallest domain when the membership degree value is the highest.

b = least degree in the domain.

Membership Function

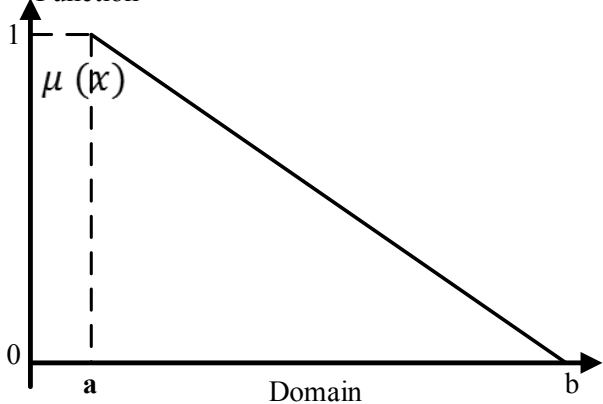

FIGURE 2. Downward Linear Membership Function.

3. The Triangle Membership Function is a curve with 3 parameter points, that are a, b, and c, as shown in the equation 3 and FIGURE 3 [25].

Membership Function

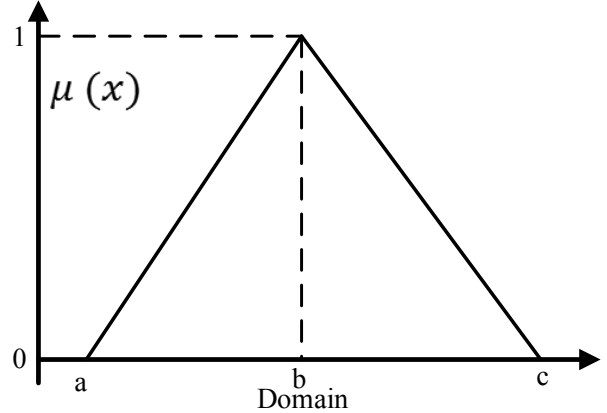

FIGURE 3. The Triangle Membership Function.

$$\begin{cases} 0; & x \leq a \text{ or } x \geq c \\ \frac{x-a}{b-a}; & a \leq x \leq b \\ \frac{b-x}{c-b}; & b \leq x \leq c \end{cases} \quad (3)$$

Description:

a = the smallest domain when membership degree is highest.

c = The smallest degree of membership in the domain.

4. The Membership Function of the Trapezoid is almost the same as the shape of a triangle, but there are differences at some points with the domain of membership degree with a value of 1. This can be shown by the equation 4 and confirmed in the FIGURE 4 [26].

Membership Function

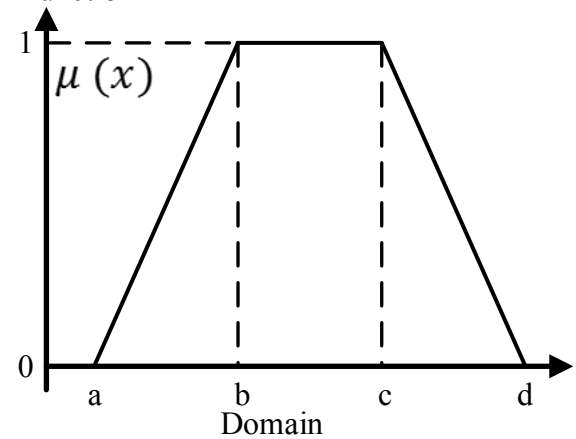

FIGURE 4. The Membership Function of the Trapezoid.

$$\begin{cases} 0; & x \leq a \text{ or } x \geq d \\ \frac{x-a}{b-a}; & a \leq x \leq b \\ 1; & b \leq x \leq c \\ \frac{d-x}{d-c}; & c \leq x \leq d \end{cases} \quad (4)$$

- b. Implication Function Application**
In the Mamdani method, the implication function used is the MIN function which states the relationship between input and output variables. The connecting operator between rules is AND whose input and output are represented by IF-THEN [25].
- c. Rules Composition**
The composition rule used in the Mamdani method is the MAX rule which produces a solution from the maximum value of the rule [26].
- d. Defuzzification**
The output of the Mamdani method defuzzification in the form of numbers in the domain of the fuzzy set [26].

2) EXPERIMENT

Testing is carried out after the tool has been designed and made. This study used five subjects as a test material, with three of them aged 22 and 23 years [22], with measurements taken before eating. While the other two use goods. The results

Mass Index. After that, the Body Mass Index was compared with manual calculations and MATLAB [26]. Tests for the body fat percentage were carried out on four different subjects aged 22 and 23 years before eating. The body fat percentage content was determined by a predictive formula based on the British Journal of Nutrition. Then the results of the body fat percentage content are compared with a tool called Body Monitor. The measurement and calculation data are tested to send to the website. The test results showed that each data was success sent with a long time of 16-18 seconds.

B. THE DIAGRAM BLOCK

FIGURE 5 shows that the input process consists of a load cell sensor, an ultrasonic sensor HCSR-04, and input datum by a keypad. Datum is processed by the Arduino Mega 2560 with data inputted via the keypad to be displayed first via the LCD [24], [27]. Then automatically, the load cell and ultrasonic will take measurements on the subject [29]. The values of weight and height were used as the determination of the Body Mass Index [30]. The Body Mass Index results are used to determine

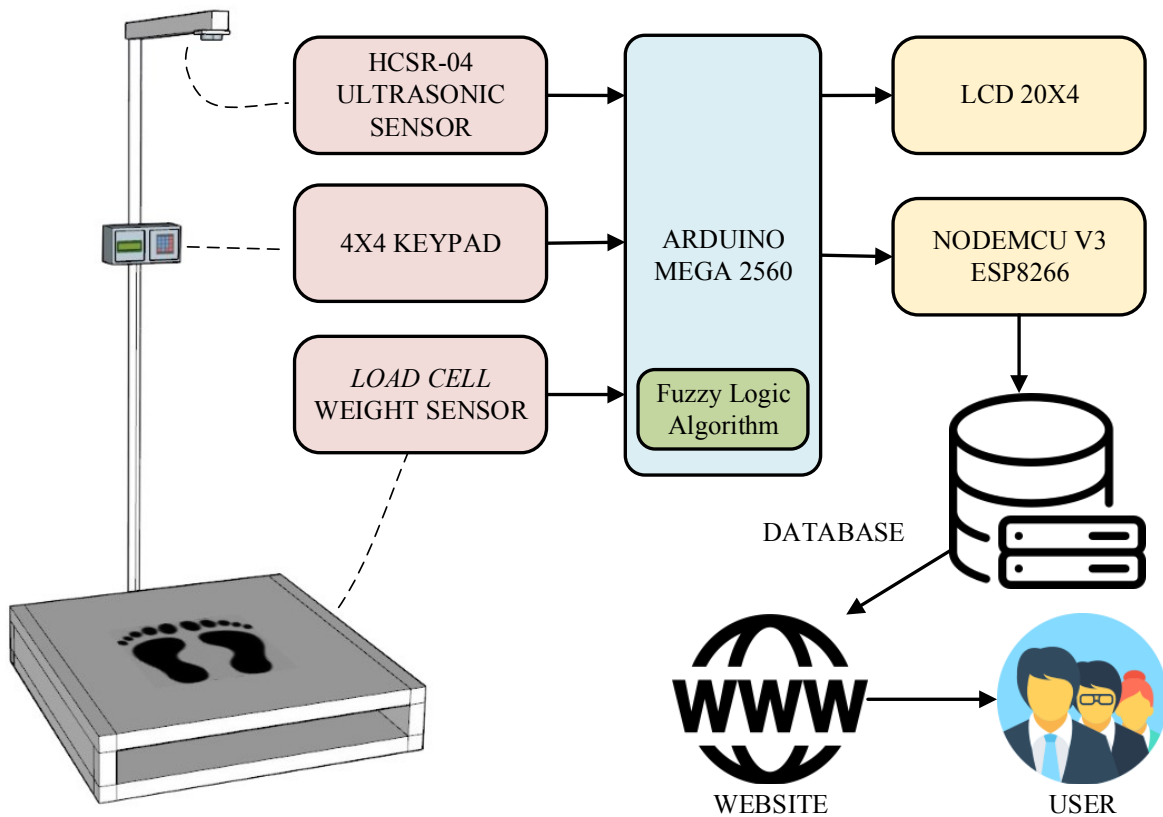

FIGURE 5. The experimental setup and the design diagram block.

of the load cell test as a measure of body weight, compared with analog weight scales. The ultrasonic sensor HCSR-04 results as a height measurement were compared with manual measurements. The measurement results are used for Body

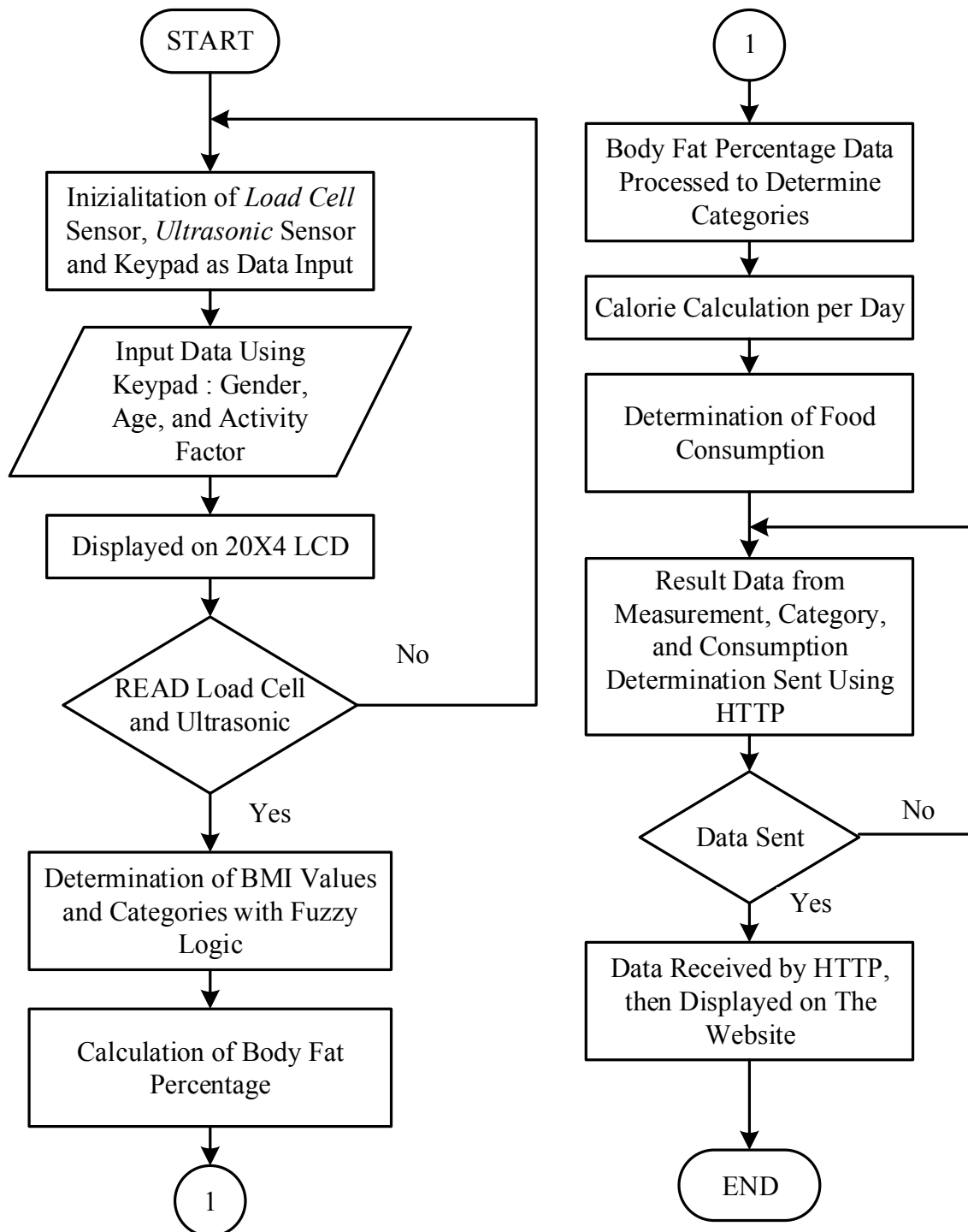

FIGURE 6. Flowchart of the entire Body Mass Index classification system using the fuzzy method and the body fat percentage for database-based calorie consumption information.

the value and category of the percentage of fat content. Body Mass Index, body fat percentage, and type of activity are used as a determinant of calorie needs in 1 day as information related to food that must consume. All data is sent to the website using the NodeMCU ESP8266 module, as a Wi-Fi module, to be stored and displayed so it can be viewed anytime

and anywhere. Moreover, the measurement and calculation data are displayed on the LCD as a temporary display.

C. THE FLOWCHART

1) FLOWCHART

The overall flowchart of the Body Mass Index classification system using the fuzzy method and fat content for calorie consumption information is shown in FIGURE 6. The first process is an initialization from the load cell pin, HCSR-04 ultrasonic pin, and keypad as input data for name, age, gender, activity type, which are displayed on the LCD [31]. After the data appears, the load cell and ultrasonic automatically read the data from the subject/target. If the load cell and ultrasonic sensors do not read the data, the process will return to the initialization of each input component. However, when the load cell and ultrasonic successfully read the data, the next process is to determine the Body Mass Index (BMI) value and its category using the Mamdani fuzzy method [31]. Body Mass Index values are combined with age data into the body fat percentage formula to determine the body fat percentage category. These data are a determinant of calorie needs in 1 day that uses to determine what foods can be consumed [13]. Keypad input data and measurement results are sent to the internet with the help of the NodeMCU ESP8266 module as a Wi-Fi module using HTTP. If the datum is sent to the internet, the datum will appear on the website as a database [25].

However, if the datum is not sent, it will return to the sending process.

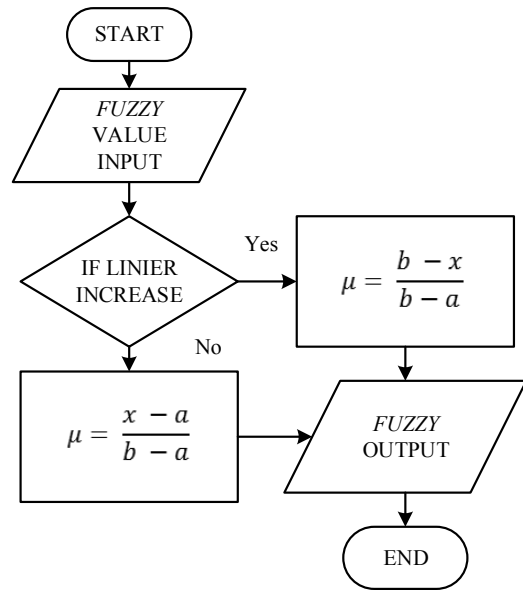

FIGURE 7. Flowchart of fuzzification determination of Body Mass Index values and categories.

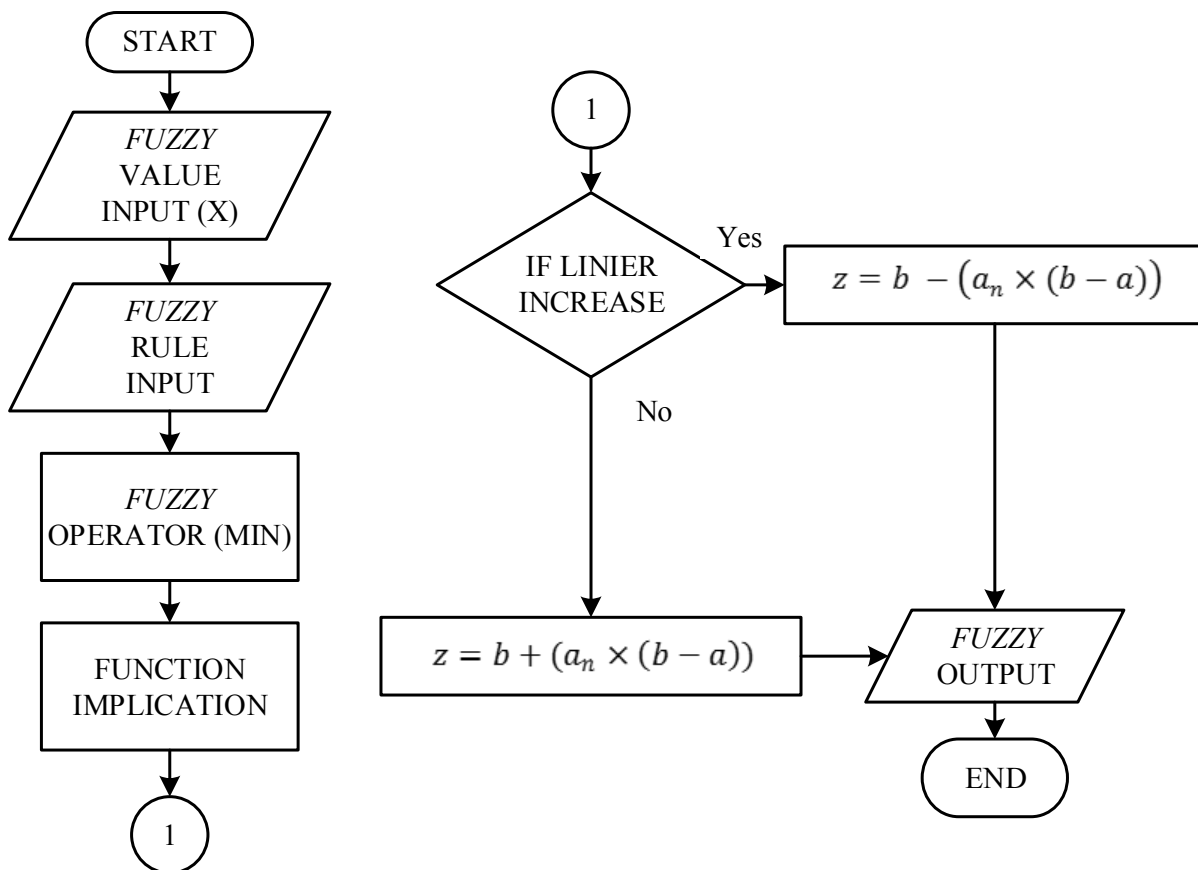

FIGURE 8. Flowchart of inference system for determining values and categories of Body Mass Index.

2) FUZZY LOGIC FLOWCHART

The initial process of the Mamdani fuzzy method is fuzzification, which is shown in FIGURE 7. Fuzzification is the process of entering fuzzy variables as input and output consisting of several fuzzy sets and determining the membership function of the fuzzy sets.

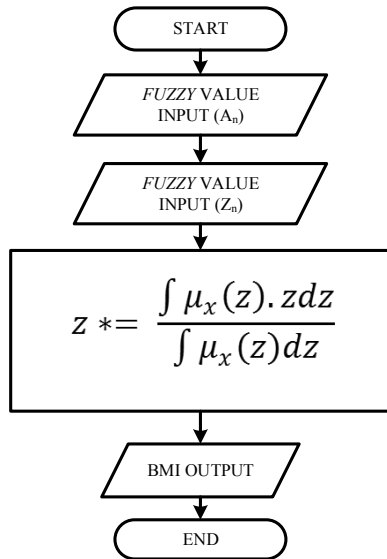

FIGURE 9. Flowchart of defuzzification determination of Body Mass Index values and categories.

The fuzzy variables in this study are data on weight, height, and Body Mass Index. The data on weight, height, and Body Mass Index are then determined by the membership function with the formula $\mu(x) = (b-x)/(b-a)$ or $\mu(x) = (x-a)/(b-a)$. The results of the membership function are used in the inference system, in order to get fuzzy output in firm values. The next process is the Inference System which is based on a set of fuzzy inputs and fuzzy rules have created using the IF-THEN rules, as shown in FIGURE 8. This study was used the Mamdani method or also called the Min-Max method [10]. The Min-Max method is done by finding the minimum value of each existing rule [8]. From several rules with the minimum value, the implication function is determined by finding the maximum value that comes from the combined consequences of each rule [26]. That is useful for narrowing the rules according to the input data and getting the desired output value. The final process from the fuzzy logic results is defuzzification, as shown in FIGURE 9. The results of the inference system in the previous process are in the form of several values arranged in the form of a fuzzy area. These values are processed using the Center of Area (CoA) method [26]. The Center of Area method is a method that takes the center of the fuzzy area to get a crisp solution [33]. So, based on the input weight and height, the values and categories of Body Mass Index are obtained.

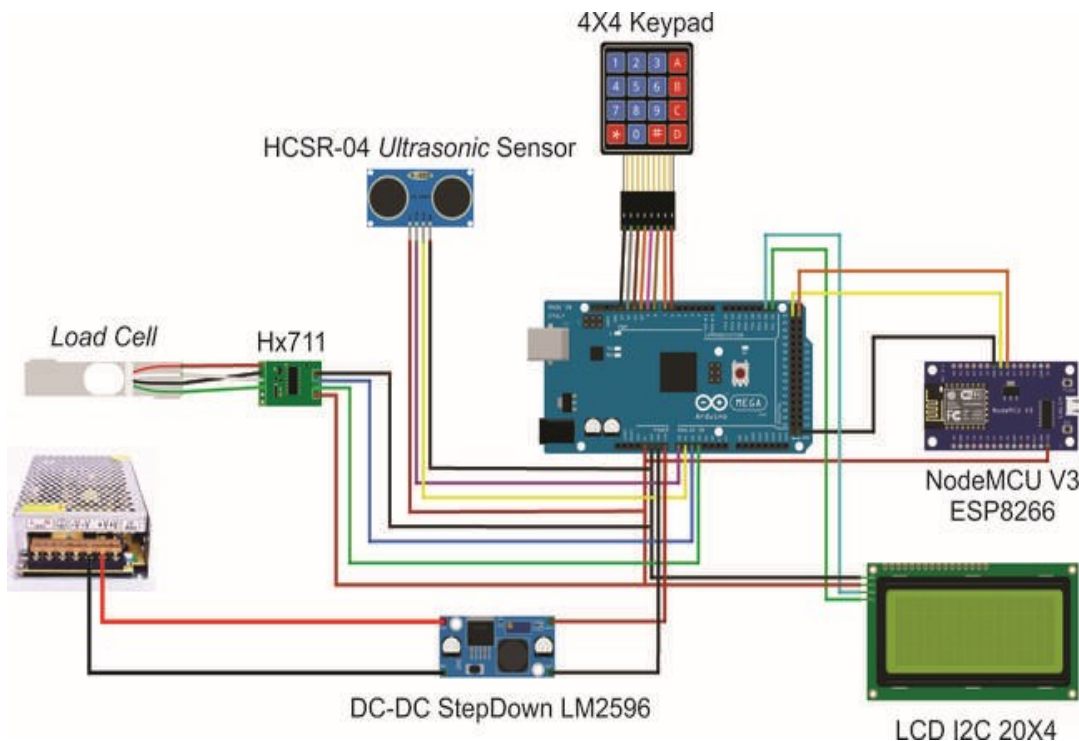

FIGURE 10. The whole set of tools.

D. HARDWARE DESIGN

The connection design between components is shown in FIGURE 10, which consists of components as inputs, microcontrollers, and outputs. The input component consists of a 4X4 keypad which is connected to digital pins 13-6 Arduino Mega 2560, which consists of pins 13-10 as row configurations 4-1 on the keypad and pins 6-9 as column 4-1 configuration on the keypad. The next input component is the ultrasonic sensor HCSR-04 which is connected to Arduino Mega via its digital pins, namely the VCC pin is connected to the 5V pin, the Trigger pin as the transmitter is connected to pin A0, the Echo pin as the receiver is connected to pin A1, and the GND is connected to pin GND. The last input component is a load cell weight sensor which has 4 wires with black, white, green, and red colors connected to the HX711 amplifier, each on pins E+, E-, A, and A+. The GND pin of the HX711 amplifier is connected to the Arduino Mega 2560, the DT pin is connected to the A2 pin, the SCK pin is connected to the A3 pin, and the VCC pin is connected to the 5V pin. While the output components in this study include a 20X4 LCD which is connected to the Arduino Mega 2560, namely the SDA (Serial Data) and SCL (Serial Clock) pins with 20 (SDA) and 21 (SCL) pins, as well as the NodeMCU ESP8266 which is connected to the ESP8266. These pins are GND pin connected to GND pin, digital pin 5/GPIO 14 on MCU is connected to digital pin 22, digital pin 6/GPIO[12 on NodeMCU is connected to digital pin 23, and VCC pin is connected with the 5V pin on the Arduino [34].

III. RESULT

A. FUZZY LOGIC

Fuzzy logic in this study aims to change the input, in the form of weight and height, into the appropriate Body Mass Index output. Each rule in this research forms the IF-THEN (“cause-effect”) function as the antecedent associated with the conjunction AND [12], [35], with a minimum membership value (min). So, the stages of the Mamdani fuzzy logic process include:

1) FUZZIFICATION

a. Making Variable Bodyweight.

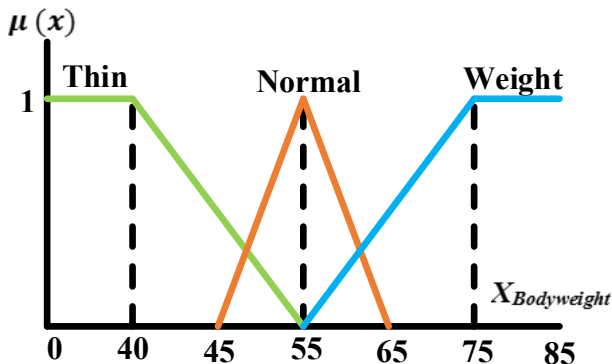

FIGURE 11. Bodyweight representative curve

The weight variable consists of three sets, namely thin, normal, and weight, as shown in the representative graph in FIGURE 11. From FIGURE 11, it can be determined the degree of membership of the weight variable, namely:

$$\mu_{thin}(x) = \begin{cases} 1, & x \leq 40 \\ \frac{55-x}{55-45}, & 40 \leq x \leq 55 \\ 0, & x \geq 55 \end{cases} \quad (5)$$

$$\mu_{normal}(x) = \begin{cases} 0, & x \leq 45 \text{ or } x \geq 65 \\ \frac{x-45}{55-45}, & 45 \leq x \leq 55 \\ \frac{65-x}{65-55}, & 55 \leq x \leq 65 \end{cases} \quad (6)$$

$$\mu_{weight}(x) = \begin{cases} 0, & x \leq 55 \\ \frac{x-55}{75-55}, & 55 \leq x \leq 75 \\ 1, & x \geq 75 \end{cases} \quad (7)$$

b. Making Variable Body Height

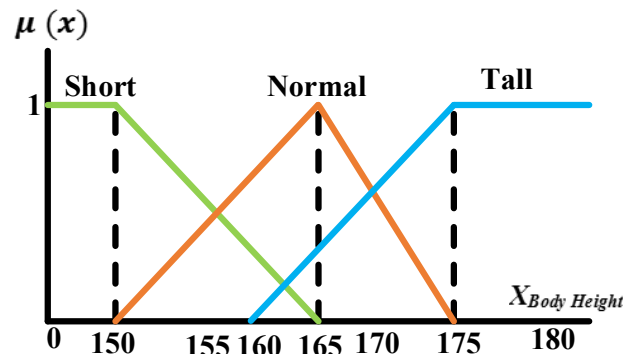

FIGURE 12. Height representative curve

The height variable consists of three sets, namely short, normal, and tall. The three variables are depicted in a representative curve shown in Figure 12.

From FIGURE 12 it can be determined the degree of membership of the height variable, namely:

$$\mu_{short}(x) = \begin{cases} 1, & x \leq 150 \\ \frac{165-x}{165-150}, & 150 \leq x \leq 165 \\ 0, & x \geq 165 \end{cases} \quad (8)$$

$$\mu_{normal}(x) = \begin{cases} 0, & x \leq 150 \text{ or } x \geq 175 \\ \frac{x-150}{165-150}, & 150 \leq x \leq 165 \\ \frac{175-x}{175-165}, & 165 \leq x \leq 175 \end{cases} \quad (9)$$

$$\mu_{tall}(x) = \begin{cases} 0, & x \leq 160 \\ \frac{x-160}{175-160}, & 160 \leq x \leq 175 \\ 1, & x \geq 175 \end{cases} \quad (10)$$

c. Making Variable Body Mass Index

Variable Body Mass Index consists of five sets, that are very thin, thin, normal, weight, and obesity. Based on these three variables, it can be shown by a representative curve depicted in FIGURE 13.

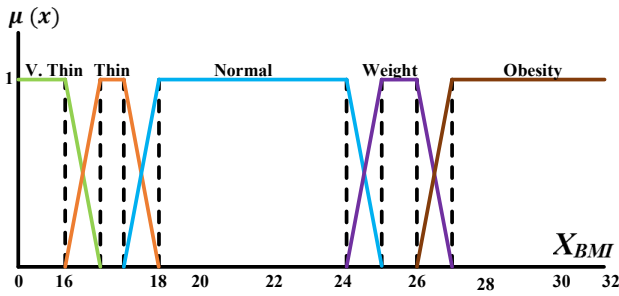

FIGURE 13. Body mass index representative curve

From FIGURE 13, it can be determined the degree of membership of the Body Mass Index variable, namely:

$$\mu_{very\ thin}(x) = \begin{cases} 1, & x \leq 16 \\ 17 - x, & 16 \leq x \leq 17 \\ 0, & x \geq 17 \end{cases} \quad (11)$$

$$\mu_{thin}(x) = \begin{cases} 0, & x \leq 16 \text{ or } x \geq 18.5 \\ x - 16, & 16 \leq x \leq 17 \\ 18.5 - x, & 17.5 \leq x \leq 18.5 \\ 1, & 17 \leq x \leq 17.5 \end{cases} \quad (12)$$

$$\mu_{normal}(x) = \begin{cases} 0, & x \leq 17.5 \text{ or } x \geq 25 \\ x - 17.5, & 17.5 \leq x \leq 18.5 \\ 25 - x, & 24 \leq x \leq 25 \\ 1, & 18.5 \leq x \leq 24 \end{cases} \quad (13)$$

$$\mu_{weight}(x) = \begin{cases} 0, & x \leq 24 \text{ or } x \geq 27 \\ x - 24, & 24 \leq x \leq 25 \\ 27 - x, & 26 \leq x \leq 27 \\ 1, & 25 \leq x \leq 26 \end{cases} \quad (14)$$

$$\mu_{obesity}(x) = \begin{cases} 0, & x \leq 26 \\ x - 26, & 26 \leq x \leq 27 \\ 1, & x \geq 27 \end{cases} \quad (15)$$

2) RULE-BASED

After determining the fuzzy set and the membership function for each input and output of the fuzzification, the next step is making fuzzy rules. The purpose of forming fuzzy rules is as an input and output statement. Each rule is a function where the operator that connects two inputs is AND and the one that maps the input-output is IF-THEN [12]. Based on the fuzzy input consisting of weight and height variables, each having three fuzzy sets, and the Body Mass Index output variable with 5 fuzzy sets, 9 rules are formed as shown in TABLE 1.

3) INFERENCE MACHINE

After the rules are formed, nine rules are processed in the application of the implication function. The application of the implication function looks for the minimum value (MIN) of the membership value of the weight and height variables in each rule [26]. Then the minimum value of the nine rules, look for the maximum value (the largest value). So, the fuzzy area is obtained on the Body Mass Index variable from several rules that have been sought for the maximum value. Based on the test results, some data were obtained, for example, the bodyweight of 67.86 kg and height of 140.57 cm.

[R7] IF Bodyweight **WEIGHT** AND Body Height **SHORT** THEN Body Mass Index **OBSESITY**.

α -predicate7 [12] = $\mu_{\text{Bodyweight WEIGHT}} \cap \mu_{\text{Body Height SHORT}}$

$$= \min(\mu_{\text{Bodyweight WEIGHT}}, \mu_{\text{Body Height SHORT}})$$

$$= \min(0.643, 1)$$

$$= 0.643$$

Based on the implication function of the seventh rule, the obesity Body Mass Index category with a value of 0.643 is obtained, which can be shown in FIGURE 14.

TABLE 1 Fuzzy Rules

Bodyweight	Body Height	BMI
IF Thin	AND Short	THEN Normal
IF Thin	AND Normal	THEN Thin
IF Thin	AND Tall	THEN Very Thin
IF Normal	AND Short	THEN Weight
IF Normal	AND Normal	THEN Normal
IF Normal	AND Tall	THEN Thin
IF Weight	AND Short	THEN Obesity
IF Weight	AND Normal	THEN Weight
IF Weight	AND Tall	THEN Normal

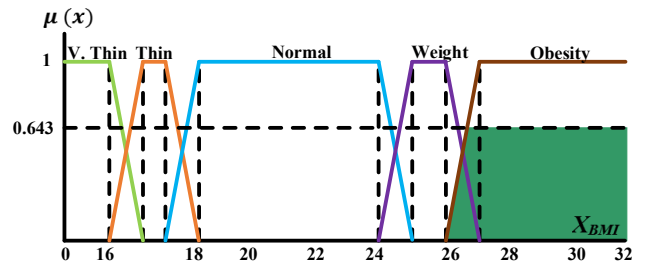

FIGURE 14. Body mass index representative curve

4) DEFUZZIFICATION

The last step in determining the firm value of the fuzzy value is defuzzification. FIGURE 15 is a graph of the results of the inference engine used for defuzzification calculations using the Center of Area (CoA) method [26].

The first step in determining defuzzification with the Center of Area is to calculate the area of each area on the graph shown in Figure 15.

$$LA_1 = \frac{a \times t}{2} = \frac{0.643 \times 0.643}{2} = \frac{0.413449}{2} = 0.20673$$

$$LA_2 = a \times t = 5.357 \times 0.643 = 3.444551$$

$$L_{total} = 3.6512755$$

The next step is to determine the moment in each area on the graph

$$M_1 = \int_{26}^{26.643} (z - 26)z \, dz = 5.4634529$$

$$M_2 = \int_{26.643}^{32} (0.643)z \, dz = 100.9994021465$$

$$M_{total} = 106.462855$$

Based on the values L_{total} and M_{total} , the defuzzification can be calculated and the categories determined as follows:

$$z^* = \frac{\int \mu_x(z)z \, dz}{\int \mu_x(z) \, dz} = \frac{106.462855}{3.6512755} = 29.1577 \text{ (Obesity)}$$

From the description of the calculation and determination of fuzzy categories above, it can be shown in TABLE 2 as the results of the Mamdani fuzzy test compared with the program and MATLAB.

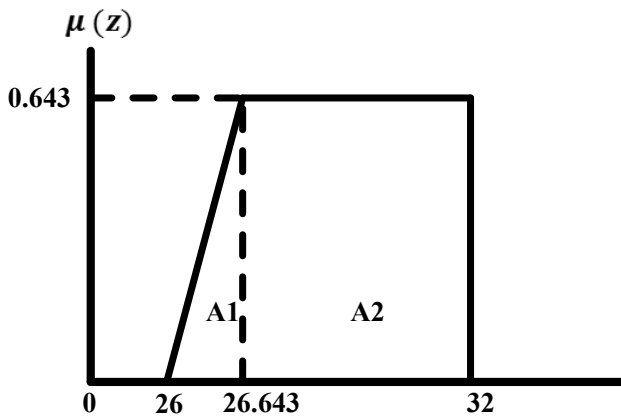

FIGURE 15. Composition result area

TABLE 2
Mamdani fuzzy method test results
Body Mass Index Calculation

Manual	MATLAB	Arduino Program
(Very Thin) 8.2076493034	(Very Thin) 8.36	(Very Thin) 8.51
(Thin) 18.2246448255	(Thin) 17.70	(Thin) 17.97
(Normal) 23.93187788	(Normal) 24.50	(Normal) 24.83
(Weight) 24.99784225	(Weight) 25.10	(Weight) 25.16
(Obesity) 29.15771626	(Obesity) 30.20	(Obesity) 30.60

B. BODY FAT PERCENTAGE

The body fat percentage with a predictive formula by the British Journal of Nutrition on this system, compared with one of the tools for measuring the body fat percentage called Body Monitor.

TABLE 3
Comparison of values and categories for measuring the body fat percentage
Body Fat Percentage

BMI	Body Monitor	System
23.87	(Normal) 27.9%	(Normal) 28.304%
30.57	(Weight) 29.8%	(Weight) 31.174%
26.24	(Quite fat) 20.9%	(Quite fat) 20.578%
26.94	(Quite fat) 20.2%	(Quite fat) 20.828%

The results of measuring the body fat percentage in this system are grouped into several categories, which will be compared with the Body Monitor tool to determine the accuracy of the tool. The results of the comparison of determining the value

and category of body fat percentage based on the British Journal of Nutrition and the Body Monitor tool are shown in TABLE 3 below.

C. DATABASE

In this system, the database functions to display all data stored as the result of data processing on the Arduino Mega 2560, including name, gender, age, and activity factors entered via the 4X4 keypad. In addition, there is also weight and height data that is inputted through the load cell weight sensor and ultrasonic sensor HCSR-04. Then the data is processed to obtain the Body Mass Index category which is determined by the fuzzy Mamdani method, the category of body fat percentage, BMR, and foods that can be consumed. The appearance of the website as a result of storing database data is shown in TABLE 4.

IV. DISCUSSION

Based on the stages of fuzzification to defuzzification, the process of determining the value and category of Body Mass Index manually compared to MATLAB and the Arduino program is summarized in the form of a table shown in TABLE 2. From TABLE 2, it can be concluded that there is a difference in values between the Arduino program on the system, MATLAB, and manual calculations. This difference is caused by rounding in the MATLAB calculations and the Arduino program. However, this difference does not affect the Body Mass Index category because it is still in the same category range. So, the fuzzy method in this system works well and works following the theory and test results based on MATLAB. Because the Body Mass Index can only determine a person's nutritional status, without knowing the composition of body fat as a factor to be considered in a diet pattern, it is necessary to measure the body fat percentage based on the British Journal of Nutrition [7], with the formulas:

$$\text{Male} = (1.20 \times \text{BMI}) + (0.23 \times \text{Age}) - 10.8 - 5.4 \% \quad (16)$$

$$\text{Female} = (1.20 \times \text{BMI}) + (0.23 \times \text{Age}) - 5.4 \% \quad (17)$$

Based on the above formula, the resulting values and categories of body fat percentage are compared with the Body Monitor tool, as shown in TABLE 3. Similar to the results of the Body Mass Index, there is a difference in numbers due to the difference in rounding between the system and the Body Monitor tool. However, the difference does not affect the category of body fat percentage. That is because the value results are still in the same category range. So, it can be concluded that the system can work well and follow the tools used as a reference in determining the value and category of the percentage of fat content. All input and output data results have been processed by the Arduino Mega 2560 microcontroller displayed on a website which is also used as data storage. All data has been successfully shown on the website, as shown in TABLE 4. The date, month, year, and

TABLE 4
Database View

Svr.Time	Svr. Seq	Name	Gender	Age	Activity	HTTP User Agent	Body weight	Body Height	BMI	Body Fat	BMR	Food
2021-08-08 20:13:58	6340	EDI	0.00	22	Mild	ESP8266HTTPClient	61.51	167.36	Normal	Quite Fat	1376.18	Lontong Soto Makassar
2021-08-08 20:13:48	6339	EDI	0.00	22	Mild	ESP8266HTTPClient	63.79	166.29	Normal	Quite Fat	1386.73	Lontong Soto Makassar
2021-08-08 20:12:41	6335	EDI	0.00	22	Mild	ESP8266HTTPClient	59.64	166.76	Normal	Quite Fat	1359.51	Lontong Soto Makassar
2021-08-08 20:12:34	6334	EDI	0.00	22	Mild	ESP8266HTTPClient	58.69	168.33	Normal	Quite Fat	1361.24	Lontong Soto Makassar
2021-08-08 20:11:21	6332	BILY	0.00	23	Heavy	ESP8266HTTPClient	84.02	178.45	Normal	Quite Fat	2146.43	Nasi Putih Ayam Panggang
2021-08-08 20:11:18	6331	BILY	0.00	23	Heavy	ESP8266HTTPClient	84.02	178.45	Normal	Quite Fat	2136.87	Nasi Putih Ayam Panggang
2021-08-08 20:11:11	6330	BILY	0.00	23	Heavy	ESP8266HTTPClient	84.39	176.66	Normal	Quite Fat	2126.93	Nasi Putih Ayam Panggang
2021-08-08 20:11:06	6329	BILY	0.00	23	Heavy	ESP8266HTTPClient	84.65	174.97	Normal	Quite Fat	2117.73	Nasi Putih Ayam Panggang
2021-08-08 20:10:50	6326	BILY	0.00	23	Heavy	ESP8266HTTPClient	82.74	176.22	Normal	Quite Fat	2134.54	Nasi Putih Ayam Panggang
2021-08-08 20:10:28	6325	BILY	0.00	23	Heavy	ESP8266HTTPClient	83.05	178.1	Normal	Quite Fat	2132.98	Nasi Putih Ayam Panggang
2021-08-08 20:10:20	6324	BILY	0.00	23	Heavy	ESP8266HTTPClient	83.28	177.59	Normal	Quite Fat	2108.59	Nasi Putih Ayam Panggang
2021-08-08 20:10:14	6323	BILY	0.00	23	Heavy	ESP8266HTTPClient	83.8	173.59	Normal	Quite Fat	2106.43	Nasi Putih Ayam Panggang
2021-08-08 20:08:10	6314	DYAH	1.00	22	Normal	ESP8266HTTPClient	59.8	159.19	Normal	Normal	1808.68	Ubi Rebus Talas Rebus
2021-08-08 20:08:07	6313	DYAH	1.00	22	Normal	ESP8266HTTPClient	59.55	159.52	Normal	Normal	1804.18	Ubi Rebus Talas Rebus
2021-08-08 20:08:00	6312	DYAH	1.00	22	Normal	ESP8266HTTPClient	59.44	157.09	Normal	Normal	1793.97	Ubi Rebus Talas Rebus
2021-08-08 20:07:55	6311	DYAH	1.00	22	Normal	ESP8266HTTPClient	59.44	157.09	Normal	Normal	1793.97	Ubi Rebus Talas Rebus
2021-08-08 20:06:17	6300	DYAH	1.00	22	Normal	ESP8266HTTPClient	60.98	157.79	Weight	Normal	1831.57	Ubi Rebus Talas Rebus

time display functions to monitor changes and developments in weight, height, Body Mass Index, percentage of fat content, calorie needs, and edible foods. When the tool is used, the system begins to determine the Body Mass Index value based on the results of measurements of weight and height. Because the Body Mass Index and the percentage of fat content are interrelated, the Body Mass Index value is used to measure body fat percentage. This relationship is also used in determining the appropriate food for consumption, based on the results of measurements of Body Mass Index and body fat percentage. All measurement results and suitable food for consumption will be displayed and stored on the website.

V. CONCLUSION

This paper aims to design and manufacture a tool fuzzy logic method as a system in determining the values and categories of Body Mass Index (BMI) automatically. The results show

that the determination of Body Mass Index and the body fat percentage can produce the same category as the reference used. The difference in numbers in values is caused by rounding the results of calculations from manual calculations, MATLAB, and the Body Monitor tool. Because the Body Mass Index and the body fat percentage are interrelated, it is used in determining the food that can be consumed. All data is sent to the internet to be stored as a database and shown on the website, so it can view anytime and anywhere. However, this system needs development in several parts, that is determining the body fat percentage using the Bioelectrical Impedance Analysis (BIA) method, using methods in determining food, and an internet display in the form of an application that can give notification as a notice that measurements have made and the data is stored.

REFERENCES

[1] A. A. G. Ekayana, I. N. B. Hartawan, I. G. M. N. Desnanjaya, and I. D. M. A. B. Joni, "Body mass index measurement system as a desktop-based nutrition monitor," in *Journal of Physics: Conference Series*, Feb. 2020, vol. 1469, no. 1. doi: 10.1088/1742-6596/1469/1/012104.

[2] S. E. Putri and A. I. Lubis, "The Relationship Between Body Mass Index with Body Fat Percentage of Participants EXPO 2021 Universitas Teuku Umar," *Journal of*

- Nutrition Science*, vol. 2, no. 1, p. 19, May 2021, doi: 10.35308/jns.v2i2.3567.
- [3] F. Q. Nuttall, "Body mass index: Obesity, BMI, and health: A critical review," *Nutrition Today*, vol. 50, no. 3. Lippincott Williams and Wilkins, pp. 117–128, May 17, 2015. doi: 10.1097/NT.000000000000092.
- [4] Kementerian Kesehatan Republik Indonesia, *Peraturan Menteri Kesehatan Republik Indonesia Nomor 41 Tahun 2014 Tentang Pedoman Gizi Seimbang*. Indonesia, 2014.
- [5] A. K. Gopalakrishnan, "Recommended weight prediction system based on BMI, BMR, food calorie and a neural network," in *2017 International Conference on Intelligent Informatics and Biomedical Sciences (ICIIBMS)*, Nov. 2017, pp. 15–22. doi: 10.1109/ICIIBMS.2017.8279683.
- [6] B. Bajželj, F. Laguzzi, and E. Röss, "The role of fats in the transition to sustainable diets," *The Lancet Planetary Health*, vol. 5, no. 9, pp. e644–e653, Sep. 2021, doi: 10.1016/S2542-5196(21)00194-7.
- [7] P. Deurenberg, J. A. Weststrate, and J. C. Seidell, "Body mass index as a measure of body fatness: age- and sex-specific prediction formulas," *British Journal of Nutrition*, vol. 65, no. 2, pp. 105–114, Mar. 1991, doi: 10.1079/BJN19910073.
- [8] D. A. N. Wulandari, T. Prihatin, A. Prasetyo, and N. Merlina, "A Comparison Tsukamoto and Mamdani Methods in Fuzzy Inference System for Determining Nutritional Toddlers," in *2018 6th International Conference on Cyber and IT Service Management (CITSM)*, Aug. 2018, pp. 1–7. doi: 10.1109/CITSM.2018.8674248.
- [9] A. A. Taha and M. A. Taha, "Using Fuzzy Logic Decision Support System to Predict the Lifted Weight for Students at Weightlifting Class," *International Journal of Computer and Information Engineering*, vol. 8, no. 8, pp. 1560–1564, 2014.
- [10] M. Sunjana, "Prediction of Production Using the Fuzzy Mamdani Inference System," *International Journal of Advanced Science and Technology (IJAST)*, vol. 28, no. 6, pp. 136–139, Sep. 2019.
- [11] A. T. Khomeiny, T. Restu Kusuma, A. N. Handayani, A. Prasetya Wibawa, and A. H. Supadmi Irianti, "Grading System Recommendations for Students using Fuzzy Mamdani Logic," in *4th International Conference on Vocational Education and Training, ICOVET 2020*, Sep. 2020, pp. 273–277. doi: 10.1109/ICOVET50258.2020.9230299.
- [12] F. Sari, Desyanti, T. Radillah, S. Nurjannah, Julimar, and J. Y. Pakpahan, "Examining child obesity risk level using fuzzy inference system," *International Journal of Public Health Science*, vol. 10, no. 3, pp. 679–687, Sep. 2021, doi: 10.11591/ijphs.v10i3.20928.
- [13] I. M. Lopes, B. M. Silva, J. J. P. C. Rodrigues, J. Lloret, and M. L. Proenca, "A mobile health monitoring solution for weight control," in *2011 International Conference on Wireless Communications and Signal Processing (WCSP)*, Nov. 2011, pp. 1–5. doi: 10.1109/WCSP.2011.6096926.
- [14] N. Ismail *et al.*, "WEB-BASED CALORIE INFORMATION SYSTEM," vol. 10, 2015, [Online]. Available: www.arpnjournals.com
- [15] C. Kim and S. Youm, "Development of a Web Application Based on Human Body Obesity Index and Self-Obesity Diagnosis Model Using the Data Mining Methodology," *Sustainability*, vol. 12, no. 9, p. 3702, May 2020, doi: 10.3390/su12093702.
- [16] Dr. M. Kannan, K. Tharanitharan, A. Sreeba, Y. Nandhini, T. Pavithrakumar, and Ms. T. Akila, "Mechanised Body Mass Index (BMI) Calculator Using PIC 16F877A," *International Journal for Research & Development in Technology (IJRDT)*, vol. 7, no. 3, pp. 734–736, Mar. 2017.
- [17] D. Syahputra, Tulus, and Sawaluddin, "The Accuracy Of Fuzzy Sugeno Method With Antropometry On Determination Natural Patient Status," in *Journal of Physics: Conference Series*, Aug. 2017, pp. 1–7. doi: 10.1088/1742-6596/930/1/012022.
- [18] A. D. A. Karim, N. A. M. Lazam, N. A. Mohd Yahya, and S. Abdul Rahman, "Portable Real-Time BMI Nutritional Advice," in *IOP Conference Series: Materials Science and Engineering*, Mar. 2021, p. 012017. doi: 10.1088/1757-899X/1176/1/012017.
- [19] M. A. Riyadi, A. Nugraha, M. B. Santoso, D. Septaditya, and T. Prakoso, "Development of Bio-impedance Analyzer (BIA) for Body Fat Calculation," Apr. 2017. doi: 10.1088/1757-899X/190/1/012018.
- [20] T. J. Erinle, D. H. Oladebeye, and I. B. Ademiloye, "Parametric Design of Height and Weight Measuring System," *IJIREICE*, vol. 8, no. 7, pp. 22–34, Jul. 2020, doi: 10.17148/ijireice.2020.8705.
- [21] M. O. Akindele, J. S. Phillips, and E. U. Igumbor, "The relationship between body fat percentage and body mass index in overweight and obese individuals in an urban African setting," *Journal of Public Health in Africa*, vol. 7, no. 1, pp. 15–19, 2016, doi: 10.4081/jphia.2016.515.
- [22] A. Dwi Elisanti, R. Ayuninghemi, and E. Tri Ardianto, "Prototype Design of Body Mass Index Measurement for Adolescence to Prevent Chronic Energy Deficiency in Pregnancy Based on Arduino," 2021, doi: 10.26630/JK.V4I2.84.
- [23] E. C. Abana, "BMI Assessment Machine with Recommended Ideal Weight," *International Journal of Advanced Trends in Computer Science and Engineering*, vol. 9, no. 3, pp. 4163–4167, Jun. 2020, doi: 10.30534/ijatcse/2020/247932020.
- [24] R. K. Jain, B. Gupta, M. Ansari, and P. P. Ray, "IOT Enabled Smart Drip Irrigation System Using Web/Android Applications," in *2020 11th International Conference on Computing, Communication and Networking Technologies (ICCCNT)*, Jul. 2020, pp. 1–6. doi: 10.1109/ICCCNT49239.2020.9225345.
- [25] E. F. Yogachi, V. M. Nasution, and G. Prakarsa, "Design and Development of Fuzzy Logic Application Mamdani Method in Predicting The Number of Covid-19 Positive Cases in West Java," *IOP Conference Series: Materials Science and Engineering*, vol. 1115, no. 1, p. 012031, Mar. 2021, doi: 10.1088/1757-899X/1115/1/012031.
- [26] J. Nugroho, L. Linawati, and T. Mahatma, "Analysis of Lecturers Competency Performance Evaluation using Fuzzy Modeling," *International Journal of Active Learning*, vol. 4, no. 2, pp. 99–113, Oct. 2019.
- [27] D. S. Candra, Z. Syahlan, and E. Widodo, "DESIGN AND DEVELOPMENT OF THE MEASURING OF THE BODY MASS INDEX TO THE INDONESIA NAVY BASED ON VISUAL STUDIO," *International Journal of ASRO*, vol. 10, no. 2, pp. 116–124, Jul. 2019.

- [28] O. O. Patrick, M. A. Kazeem, and A. A. Olumuyiwa, "Development, Implementation and Usage of an Automated Body Mass Index (ABMI) System," 2020. [Online]. Available: www.globalscientificjournal.com
- [29] S. M. Omair, M. F. Shamim, A. Desai, N. Shahid, G. Munir, and M. Z. Ul Haque, "Digital and Analog Body Mass Index Calculating Device: A comparative study," *Indian Journal of Science and Technology*, vol. 10, no. 45, pp. 1–5, Dec. 2017, doi: 10.17485/ijst/2017/v10i45/120632.
- [30] I. E. Owolabi, V. A. Akpan, and O. P. Oludola, "A Low-Cost Automatic Body Mass Index Machine: The Design, Development, Calibration, Testing and Analysis," 2021. [Online]. Available: <http://www.aiscience.org/journal/ijbcshttp://creativecommons.org/licenses/by/4.0/>
- [31] S. Husain, Y. Ahmad, M. Sharma, and S. Ali, "Comparative Analysis of Defuzzification Approaches from an Aspect of Real life problem," vol. 19, no. 6, pp. 19–25, doi: 10.9790/0661-1906031925.
- [32] B. Mark *et al.*, "Development of Automated Body Mass Index Calculation Device," *International Journal of Applied Engineering Research*, vol. 11, no. 7, pp. 5195–5201, 2016, [Online]. Available: <http://www.ripublication.com>
- [33] A. Manan, V. Wiley, and T. Lucas, "Programmer Selection Using Modified Fuzzy Mamdani Method," *Lontar Komputer : Jurnal Ilmiah Teknologi Informasi*, p. 108, Aug. 2019, doi: 10.24843/lkjiti.2019.v10.i02.p05.