

Manuscript received October 8, 2021; revised October 26, 2021; accepted November 6, 2021; date of publication November 7, 2021

Digital Object Identifier (DOI): <https://doi.org/10.35882/ijeemi.v3i4.3>

This work is an open-access article and licensed under a Creative Commons Attribution-ShareAlike 4.0 International License ([CC BY-SA 4.0](https://creativecommons.org/licenses/by-sa/4.0/))



Monitoring on Portable Baby Incubator Based on Microcontroller and Notification Using Short Message Service (SMS)

M. Irmansyah, Efrizon, Era Madona, and Anggara N

Jurusan Teknik Elektro, Politeknik Negeri Padang, 25168, Padang – Sumatera Barat, Indonesia

Corresponding author: emadona38@gmail.com

ABSTRACT Portable incubator was one solution to help the premature baby. In general, the baby in the incubator is monitored by the observer manually. This research aimed to apply a microcontroller, temperature sensor, weight sensor, heart rate sensor, and GSM module to monitor and notify the premature babies' condition in portable incubators. The observation can be done by reading the display on LCD and SMS. The hardware used consists of a DS18B20 sensor, Load Cell, Pulse Heart Rate Sensor, Buzzer, LCD, and SIM800L Module. The results showed that the Pulse sensor and DS18B20 sensor could measure and detect the baby's heart rate body temperature and are displayed on the LCD with an average error of 4.354% and 1.437%. The loadcell sensor can detect weight with an error of 2.16%. The duration of sending SMS to Smartphone is 8s for each delivery. SMS was sent if the patient's conditions were weak and critical. Hopefully, these monitoring and notification tools can immediately inform the baby's state in the incubator.

INDEX TERMS Incubator, Microcontroller, Short Message Service, Load Cell.

I. INTRODUCTION

Globally 1.1 million children died in the first month of life in 2013. There are approximately 3000 newborn deaths every day, amounting to 47% of all child deaths under the age of 5-years, up from 40% in 1990, nearly 965,000 of all under-five child deaths are among newborn infants, babies in their first 28 days of life or the neonatal period. Every year, 125,000 child deaths before 1st birthday, and child mortality under 5 [1]. To help these babies survive outside of the womb, they will be placed in an incubator that provides the newborn with the environmental conditions needed to thrive while in the neonatal intensive care unit (NICU). Premature babies, also known as preemies, are put in an incubator with temperature in the incubator is controlled to keep the baby's body temperature where it should be. After the premature baby is moved to the incubator, they may undergo several tests. They are: Oxygen saturation monitoring measures the amount of oxygen in your child's blood, collected through a heel stick or a needle inserted into a vein and Monitoring of baby's vital signs, sensors may be taped to the baby's body to monitor blood pressure, heart rate, breathing and temperature [2][3] and body weight [4].

There have been many infant incubator projects, one of which is the infant incubator made by Raldi Artono Koestoer [5]. An infant-incubator using natural circulation and natural convection system and profiting the Buoyancy force due to the temperature difference between upper-side and lower-side, hot-air flow to the cabin where the baby's sleeping flows by itself without any force, neither a fan nor blower. The smallest power of 20-40 Watt will be sufficient to make a convenient limited environment for the newborn baby. And due to the small energy supply, the incubator doesn't need to be equipped with an electronic control system. In the dry season of the Indonesian climate, less power than 20 Watt can be used. But in the middle of the rainy season, due to lower average ambient temperature, the power of the bulb heater should be increased to 40 Watts. Many similar studies have also been conducted [6-12]. In general, the research conducted is more on monitoring [8] [10] and controlling temperature and humidity [6][7][11], whereas in addition to the temperature of the incubator, the condition of the heart rate and weight are also important factors to see the health condition of premature babies [4].

This paper designed a portable monitoring and notification tool for an incubator's body temperature, weight, and heart rate

based on a microcontroller and SMS. The incubator made using the Grashof method is based on research [5]. This study aimed to build and apply a microcontroller, heart sensor, weight, body temperature, and SIM800L to monitor the health condition of premature babies in the incubator. By using this tool, the baby's condition can be monitored and provide a warning about the baby's condition via SMS, which will be sent to the medical personnel concerned.

II. MATERIALS AND METHODS

A. EXPERIMENTAL SETUP

This study used ten ordinary people aged 16-50 years, data collection was repeated six times. This study also uses an experimental method by comparing heart rate, weight, and body temperature measurements with commercial tools.

1. MATERIALS AND TOOL

The material used consists of a DS18B20 temperature sensor, Load Cell, pulse sensor, Arduino Mega 25660 microcontrollers. The LCD serves to display the results of temperature, weight, and heart rate measurements that are read by the sensor, and the SIM800L module serves to send processed data from Arduino in the form of SMS. In this study, the research tools we used were multimeter, smartphone, and oscilloscope.

2. EXPERIMENT

In testing body temperature measurements, measurements are made by comparing the sensor to the digital thermometer measurement value. This temperature sensor is mounted on the armpit of an adult human. This weight meter consists of a loadcell sensor and an HX711 amplifier that measures the baby's weight. In this measurement, the baby's weight is replaced by the sandbag's weight with weights ranging from 1000 grams, 1200 grams, 1400 grams, 1600 grams, 1800 grams, 2000 grams, 2200 grams, 2400 grams, 2600 grams, and 2800 grams.

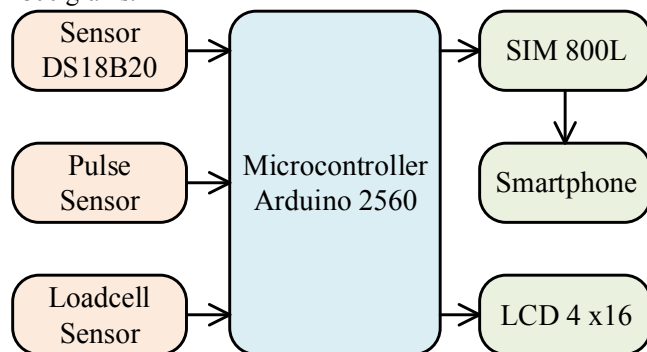

FIGURE 1. Experimental setup of Portable Incubator Monitoring Tool with Short Message Service (SMS) notifications

For heart rate testing, it consists of a Pulse Sensor, SIM800L as a notification that will send an SMS when the heart rate is less than 60 BPM or more than 110 BPM.

For the measurement of human heart rate using an adult human object. This test is done to find out how the heart sensor works (FIGURE 1). This test also aims to observe how accurate the measurement of human heart rate is by comparing the measurement results of the pulse sensor with an oximeter. In this experiment, measurements were made by placing a pulse sensor on the fingertip of an adult human hand.

B. THE DIAGRAM BLOCK

This section explained the design and manufacture of the system and how it works, both hardware and software. FIGURE 2 is a block diagram of the tool to be created. This tool has three measurement parameters: heart rate, body temperature, and baby weight, with a microcontroller as a device controller. Measuring heart rate in infants is done by placing the heart sensor on the baby's wrist. The temperature sensor measures the baby's body temperature placed in the armpit, where the normal body temperature is measured at 36°C-37.5°C per minute. The weight sensor is placed as a baby's sleeping pad to regularly weigh the baby's weight. The microcontroller functions as a signal/data processor from the input variable. The signal/data is then processed, producing output variables, and displaying on the LCD. if an abnormal condition is detected, the buzzer will sound, the doctors will receive SMS notice that the condition of the baby is abnormal through GSM modules SIM800L V.2.

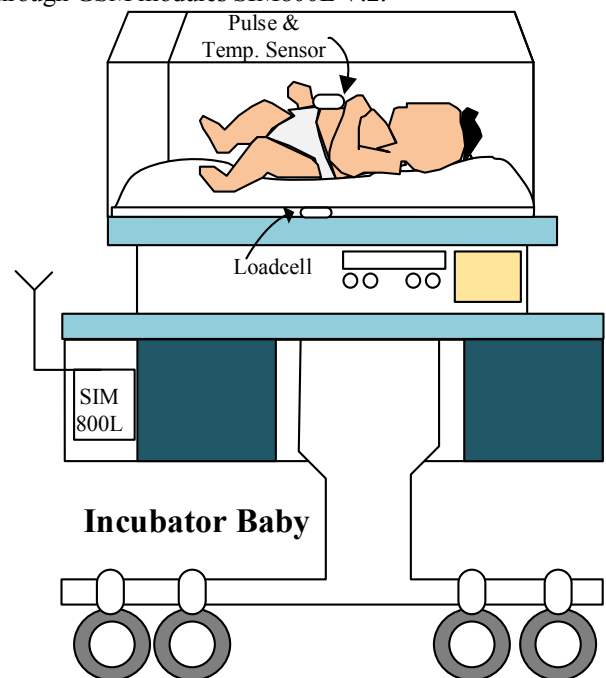

FIGURE 2. The Diagram Block of Portable Incubator Monitoring Tool with Short Message Service (SMS) notifications

C. HARDWARE DESIGN

The electronic circuit of the tool can be seen in FIGURE 3. This tool consists of pulse sensors [13-16], DS18B20 sensors [17-20] and Load Cells [21-23]. Pulse sensors work by using

light. When this sensor is placed on the surface of the skin, most of the light is absorbed or reflected by organs and tissues (skin, bones, muscles, blood), but some light will pass through body tissues if they are thin enough. If the amount of light intensity regarding the pulse sensor remains, then the signal value will be around 512 (the middle value of the 10-bit ADC range). The greater the light intensity, the higher the ADC value. The signal produced by the sensor produces a wave called photo-plethysmogram (PPG). PPG in the medical world is used to measure respiratory rate [24] and heart rate [25].

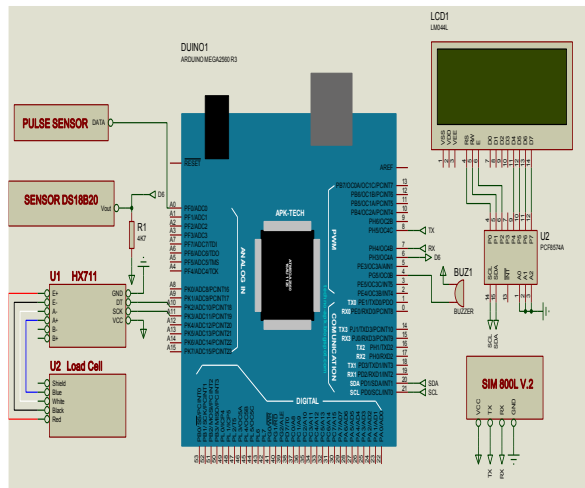

FIGURE 3. Electronic circuit of Portable Incubator Monitoring Tool with Short Message Service (SMS) notifications

When the heart pumps blood throughout the body, every pulse that occurs is accompanied by the appearance of pulse waves like shock waves travel through arteries to the capillary layer of the hand (fingers), where the pulse sensor is installed. Blood speed flows slower than pulse waves. Determination of the number of heart beats per minute (BPM = beat per minute) with this sensor is done by dividing 60000 (in milliseconds), the average value of ten IBI (interbeat intervals) that have been passed. IBI is the time difference between one point and the next point with the point value is 50% of the value of P (peak) minus T (valley) when the graph occurs extreme increase. TABLE 1 shows a baby's heart rate limits from 1 to 60 days.

TABLE 1
Baby's range BPM

Baby Age	BPM (Beat Per Minute)	Explanation
1-2 days	123-159/Minute	Heart rate also depends on the activity of baby and child. For example, when crying or pain, the heart rate can reach 180 times/minute. When a child has fever or dehydration, heart rate also increases
3-6 days	129-166/Minute	
1-3 weeks	107-182/Minute	
1-2 months	121-179/Minute	

The pulse sensor has three different function pins. Pin 1 is a data pin connected to pin A0 on the microcontroller. Pin 2 is used as a Vcc resource, and Pin 3 is used as a ground. In order to measure the baby's body temperature, the waterproof DS18B20 temperature sensor is used. This sensor has 3 pins with different functions. Pin 1 is connected to Vcc, pin 2 is connected to the ground, and pin 3 is connected to pin D6 on the microcontroller. The three pins use a pin header that can directly connect to the microcontroller. Load cell sensors are used to measure body weight. In this case, the load cell is used as a heavy sensor with four different function pins. The load cell used is equipped with an amplifier module, the 24X HX711 ADC module. The working principle of the loadcell sensor and hx711 module is that when the baby puts in, the baby will put pressure or load on the load cell sensor. This will change the resistance caused by the change in force, changed to a voltage value, so that the value of the load also changes. This change in load value is used to tell the value has reached the maximum or not. Pin 1 is connected to a + 5V voltage source, and pin two is used for data directly connected to pin A10 on the At Mega 2560 microcontroller. Pin three is a clock that is also directly connected to the A11 pin microcontroller, while pin four is used for ground. In order to display the sensor readout value on the LCD used I2C LCD, this module is controlled serially synchronously with the I2C / IIC (inter-integrated circuit) protocol or TWI (Two Wire Interface) with addresses of 0x27 and 0x37. If the baby's condition is abnormal, the buzzer will sound as an indicator for the baby's parents. The doctors will receive an SMS if the patient's condition is abnormal through the SIM800L V.2 GSM module. The condition of an abnormal baby can be seen in TABLE 2.

TABLE 2
Abnormal baby condition

No	Age (Year)	Heart rate (BPM)	Body Temp. (0C)	Condition
1	1-2 days	<123	< 35	weakened
	3-6 days	< 129	< 35	
	1-3 weeks	< 107	< 35	
2	1-2 months	< 121	< 35	weakened
	1-2 days	> 159	> 37,5	
	3-6 days	> 166	> 37,5	
3	1-3 weeks	> 182	> 37,5	critical
	1-2 months	> 179	> 37,5	
	1-2 days	> 159	< 35	
3	3-6 days	> 166	< 35	critical
	1-3 weeks	> 182	< 35	
	1-2 months	> 179	< 35	

D. FLOWCHART

The monitoring tool algorithm can be seen in **FIGURE 4**. Data from the heart rate sensor, body temperature, and body weight are then processed on the Arduino, and the sensor value will be displayed on the LCD. There are five conditions. The first condition of the sensor data value indicates under normal circumstances. The second to four conditions indicate that the baby's condition is weak and critical. If the buzzer on the device is active in this condition, an alert text will be sent to the doctor/health worker. Condition five is the condition of reading the baby's weight with a limit of 5000 grams, and if the baby's weight has reached 2500 grams, the LCD will display "the baby comes out of the incubator, and the SMS will be sent to the doctor/health worker. Programming in this study uses Arduino IDE. Programs can be seen in listings programs 1 and 2. Note: sign * can be seen in **TABLE 3**.

TABLE 3
Description of the condition of the baby on the flowchart

Condition	Heart rate	Body Temperature (°C)	Weight (gram)
1*	1-2 days : 123-159/Minute 3-6 days : 129-166/Minute 1-3 weeks : 107-182/Minute 1-2 months : 121-179/Minute	35-37.5	
2*	1-2 days < 123/Minute 3-6 days < 129/Minute 1-3 weeks < 107/Minute 1-2 months < 121/Minute	< 35	
3*	1-2 days > 159/Minute 3-6 days > 166/Minute 1-3 weeks > 182/Minute 1-2 months > 179/Minute	> 37.5	
4*	1-2 days > 159/Minute 3-6 days > 166/Minute 1-3 weeks > 182/Minute 1-2 months > 179/Minute	< 35	
5*			2500

Listing Program 1: Monitoring and notification tools on a portable incubator with microcontroller and short message service (SMS)

Declaration :

```

sensorSuhu.requestTemperatures();
suhu = sensorSuhu.getTempCByIndex(0);
berat = scale.getGram();
weight = berat;
jantung = BPM;
Stringsuhu = String(suhu, 0);
Stringberat = String(berat, 0);
Stringjantung = String(jantung, 0);
    
```

Implementation:

```

int str_lensuhu = Stringsuhu.length() + 1;
int str_lenjantung = Stringjantung.length() + 1;
int str_lenberat = Stringberat.length() + 1;
sim.println("at+cmgf=1");
if (suhu > 37.5 && jantung > 110)
{
    if (count_sms < maks_sms) {
        sim.println("AT+CMGS=\082288410xxx\r\n");
        delay(100);
        sim.print("\n\nKONDISI BAYI MELEMAH!!!");
    }
}
    
```

```

if (count_sms < maks_sms) {
    sim.println("AT+CMGS=\082288410xxx\r\n");
    delay(100);
    sim.print("\n\nKONDISI BAYI MELEMAH!!!");
}
    
```

In this study, there are five conditions, and each condition the system will notify using SMS communication. The overall system was shown in Flowchart (**FIGURE 4**).

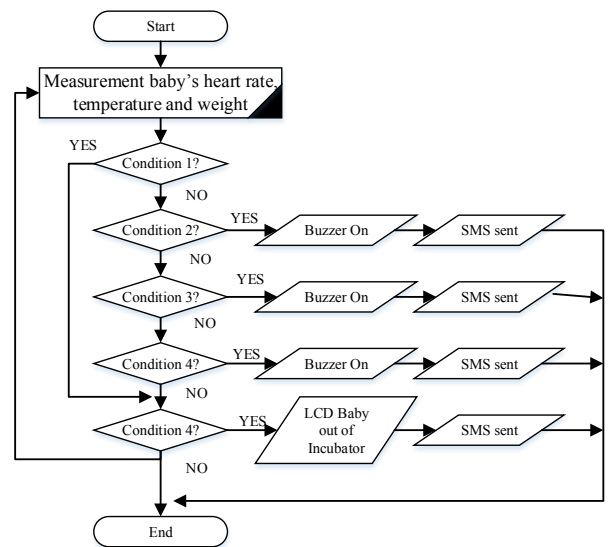

FIGURE 4. The flowchart of portable incubator monitoring tool with short message service (SMS) notifications

III. RESULT

In this section, the results of testing the tools made will be shown. First, testing of the tool as a whole is done. The results of the third reading of the sensors displayed on the LCD are then compared with manual measuring devices. Furthermore, testing system alerts, buzzers, and SMS will be active according to the conditions that have been determined. **FIGURE 5** and **FIGURE 6** is a picture of the tool as a whole.



FIGURE 5. The incubator baby prototype

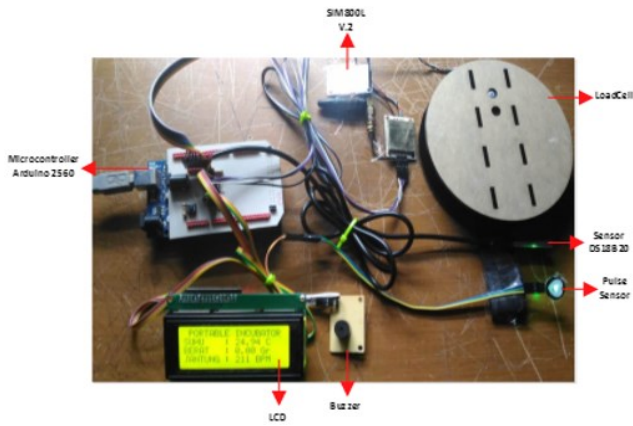

FIGURE 6. Device of Portable Incubator Monitoring Tool with Short Message Service (SMS) notifications

A. TESTING HEART RATE AND BODY TEMPERATURE CIRCUITS

This heart rate and body temperature series consists of pulse sensors, microcontrollers, buzzers, and LCDs. The reading of the BPM value (Bit Per Minute) is done periodically and is in the range 50 / minute - 180 / minute. Furthermore, if the range of readings detected is above the specified range, the buzzer will be active as a warning sign, and the LCD will display readable BPM values (FIGURE 7). The number of samples of the people tested was ten babies and children of different ages. Testing is carried out for 60 seconds/person. Tests and measurements were made by comparing the results of measurements using a Pulse Oximeter with the measurement results of the heart rate measurement circuit made. Pulse Oximeter is a device used to measure heart rate (HR = heart rate) and is usually used for premature babies or patients in special conditions. Measure the heart rate by placing a pulse sensor at the tip of the index finger, as shown in TABLE 4 and TABLE 5.



FIGURE 7. Testing heart rate and body temperature circuits of portable incubator monitoring tool with short message service (SMS) notifications

TABLE 4 Test results and measurements of the heart rate

Testing (person number)	Age (Year)	Measurement result using Pulse Oximeter (BPM)	Measurement circuit result using Pulse Sensor on LCD (BPM)	Error (%)
1	16	108	112	3.70
2	17	177	181	2.25
3	118	111	117	5.40
4	19	101	106	4.95
5	20	113	118	4.42
6	21	103	107	3.88
7	24	89	93	4.49
8	35	98	103	5.10
9	40	94	98	4.25
10	50	98	103	5.10
Error average in measurement				4.354

TABLE 5 Test results and measurements of body temperature

Testing (person number)	Age (Year)	Measurement result using Thermometer Digital (oC)	Measurement circuit result using Sensor DS18B20 on LCD (oC)	Error (%)
1	16	36.9	36.3	-1.62
2	17	38.1	37.7	-1.04
3	118	37.3	36.8	-1.34
4	19	37.4	36.8	-1.60
5	20	37.4	36.9	-1.33
6	21	37.4	36.9	-1.33
7	24	37.6	37	-1.59
8	35	37.6	37	-1.59
9	40	37.3	36.8	-1.34
10	50	37.6	37	-1.59
Error average in measurement				-1.437

B. TESTING WEIGHT MEASURING CIRCUIT

In this test, the baby's weight was replaced with a sandbag. The weight measuring circuit or series consists of loadcell sensors, HX711 amplifiers, microcontrollers, and LCDs. Load cell sensor and amplifier HX711 function to retrieve baby's weight data. Additionally, the microcontroller is used to process data. LCD displays information on baby weight measurement data and displays information that the baby's weight has reached normal weight so the baby can be removed from the incubator (FIGURE 8).



FIGURE 8. Testing weight measuring circuit of portable incubator monitoring tool with short message service (SMS) notifications.

Testing loadcell on the circuit is carried out by giving different loads the weight is 500 grams, 1000 grams, 1500 grams, 2000 grams, 2500 grams, and 3000 grams. The output voltage of the load cell is too small, so the HX711 module is needed, which acts as an amplifier and an analog data converter from the load cell to digital data. Loadcell output is connected to HX711, while HX711 output is connected to the microcontroller (TABLE 6).

TABEL 6
Result of testing and measuring weight measure circuit

Load Weight (gram)	Test	Result of Testing (gram)	Average Weight of measure (gram)	Error (%)	LCD Indicator
500	1	515	512,8	2,5	-
	2	513			
	3	512			
	4	513			
	5	511			
1000	1	1028	1027	2,7	-
	2	1028			
	3	1027			
	4	1025			
	5	1027			
1500	1	1532	1530	2	-
	2	1530			
	3	1527			
	4	1528			
	5	1535			
2000	1	2045	2041	2,1	-
	2	2038			
	3	2042			
	4	2041			
	5	2039			
2500	1	2539	2542,8	1,7	baby out of the incubator
	2	2542			
	3	2540			
	4	2545			
	5	2548			
3000	1	3065	3060,8	2	baby out of the incubator
	2	3060			
	3	3058			
	4	3060			
	5	3061			
average error on measuring				2,16%	

Load cell programming is performed by using a library of HX711 modules on Arduino, where an Arduino microcontroller will convert the digital output through the HX711 library to a heavy scale. The test results and measurements of the weight measuring circuit using loadcell sensors can be seen in Table 6.

C. TESTING GSM MODEM SERIES (SIM800L)

Testing of the SIM800L GSM Module is done to find out that this GSM modem can work properly. To communicate between networks with a microcontroller module must be set when and to what number the short text message will be sent and the contents of a short text message that want to send. It sends the conditions, namely the weakening and critical state.

SMS is sent if the patient is weak and critical can be seen in FIGURE 9.

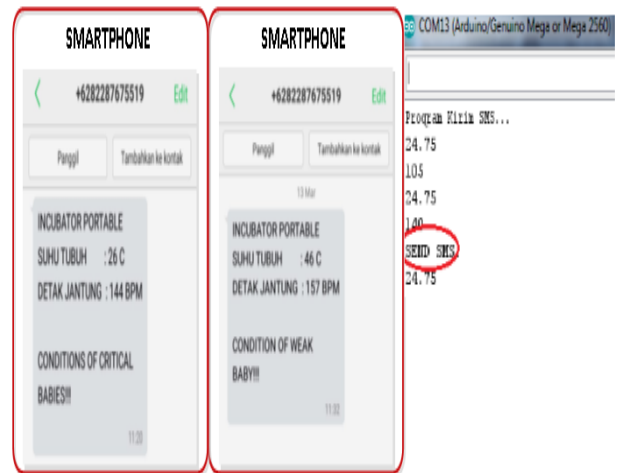

FIGURE 9. SMS notification of baby's condition if it is not in normal condition

IV. DISCUSSION

The average error can be seen in table 4 and table 5; this shows the results of testing and measuring a series of heart rate and body temperature running well. The pulse and DS18B20 sensors can measure and detect heart rate and body temperature and are displayed on the LCD with an average error of 4.354% and -1.437%. Tables 4 and 5 show the test was carried out with a qualifying age of 16-50 years. In the age range of 16-21 years, the heart rate is measured using a pulse oximeter 103-108 BPM while in the 107-112 BPM circuit. In the age range of 41-50 months, the heart rate measured using a pulse oximeter is 89-98 BPM, while in the 93-107 BPM series.

Data presented in Table 6 shows the test results. The loadcell sensor can read the measurement data, and the circuit works well. The loadcell sensor can detect the weight measured by the pressure or through the LCD. When measuring with a weight of 500 grams, the average measurement error is 2.5% of the actual load weight, the weight of the load is 1000 grams, the average measurement error is 2.7% of the actual load weight, the weight of the load is 1500 grams. - measuring the error rate of 2% of actual load weight, 2000 gram of load weight is an average measurement error of 2.1% of actual load weight, 2500 gram of load weight is an average measurement error of 1.7% of actual load weight, a weight of 3000 grams occurs an average measurement error of 2% of the actual load weight. So that the average error of the measurement of the weight of the load is 2.16%; additionally, in TABLE 5, we can also see that when testing and measuring, the weight of the load is 500 grams, 1000 grams, and 2000 and there is no information on the LCD. When the weight of 2500 grams and 3000 grams are on the LCD information, "baby out of the incubator" will appear.

This indicates that the baby's weight has reached normal weight to be put out of the incubator.

The duration of sending messages to a smartphone is around 2 seconds. The time depends on the setting of the delay. For warnings of weakening conditions and critical SMS sending takes place every 1 second and repeatedly continues before undesirable conditions occur in the patient. After the sensor reads the patient's condition, an SMS will be received by the medical staff's smartphone. The process was conducted by sending the information from Arduino to the GSM SIM800L module. It is done to see the signal sent from the Arduino TX pin to the SIM800L GSM module. This test is done by sending the command "AT + CMGF", which Arduino uses as the SMS sender command to the SIM800L module. The output voltage on SIM800L is 5 V, with the duration of sending SMS to Smartphone for 8s per shipment. The limitation of the prototype was the number of smartphones to send SMS just one number. It still develops to send on some numbers.

V. CONCLUSION

The aim of this study was to build and apply a microcontroller, heart sensor, weight, body temperature, and SIM800L to monitor the health condition of premature babies in the incubator. By using this tool, the baby's condition can be monitored and provide a warning about the baby's condition via SMS, which will be sent to the medical personnel concerned. Testing results show the whole series can work well. DS18B20 pulse sensors detect heart rate and body temperature. Additionally, the buzzer is active and sends text as a critical sign if the baby's heart rate and body temperature are read above the specified range. The loadcell sensor detects the weight measured and displays information that the baby can be removed from the incubator if the weight is above 2500 grams. So, the tool can be implemented for babies in the incubator. In future work, hopefully, SMS can be replaced by telegram or WhatsApp because the message is sent to a group, not personally.

REFERENCES

- [1] Li Liu, PhD Shefali Oza, MSc Daniel Hogan, PhD Jamie Perin, PhD Prof Igor Rudan, MD Prof Joy E Lawn, MD. Global, regional, and national causes of child mortality in 2000–13, with projections to inform post-2015 priorities: an updated systematic analysis. *The Lancet*, Volume 385, ISSUE 9966, P430-440, January 31, 2015.
- [2] D'Souza, S W, Janakova, H, Minors, D, Suri, R Waterhouse, J Appleton, G Ramesh, C Sims, D G Chiswick, M L. Blood pressure, heart rate, and skin temperature in preterm infants: associations with periventricular haemorrhage. *Archives of Disease in Childhood Fetal & Neonatal Edition* Volume 72. Issue 3.1995.
- [3] P. B. J. Deacon, *Core Curriculum Neonatal Intensive Care Nursing*. (W.B Saunders Co., Philadelphia, 1993).
- [4] Pensée Wu, Martha Gulati, Chun Shing Kwok, Chun Wai Wong, Aditya Narain, Shaughn O'Brien, Carolyn A. Chew-Graham, Ganga Verma, Umesh T. Kadam, Mamas A. Mamas. Preterm Delivery and Future Risk of Maternal Cardiovascular Disease: A Systematic Review and Meta-Analysis. *Journal of the American Heart Association*. 2018;7:e007809.
- [5] Raldi A. Koestoer, (2016). Unpatented grashof-incubator as a part of community-engagement in mechanical engineering university of Indonesia.
- [6] Velagic, J., Osmic, N., Lutvica, K., Kadic, N. Incubator System Identification and Temperature Control with PLC & HMI. 52nd International Symposium ELMAR-2010.
- [7] Wang, Ruilan. The design of temperature and humidity control system in multi incubators based on single-chip microcomputer. *Intelligence, Management Science and Electronic Commerce, AIMSEC 2011 - Proceedings*
- [8] Sahoo, Saikat, Champaty, Biswajeet, Pal, Kunal, Ray, Sirsendu S., Tibarewala, D. N. Wireless transmission of alarm signals from baby incubators to neonatal nursing station. 1st International Conference on Automation, Control, Energy and Systems - 2014, ACES 2014
- [9] Yuliant, Alvien, Kowanda, Anacostiana, Salahuddin, Nur Sultan. Rancang Aplikasi Pemantau Suhu Dan Kelembaban Pada Inkubator Bayi Berbasis Internet. *Seminar Nasional Aplikasi Teknologi Informasi*. 2015
- [10] Asmidar, Nor, Binti, Natasha, Fudzi, Mohd, Othman, Nurmiza Binti. Development of Infant Incubator for Clinic in the Rural Area of Malaysia. 2016 IEEE EMBS Conference on Biomedical Engineering and Sciences (IECBES)
- [11] Shaib, M, Rashid, M, Hamawy, L, Arnout, M, Majzoub, I El, Zaylaa, A J. Advanced Portable Preterm Baby Incubator. 2017 Fourth International Conference on Advances in Biomedical Engineering (ICABME) 2017. ISBN 9781538616420.
- [12] Muhammad Irmansyah, Era Madona, Anggara Nasution. Design And Application Of Portable Heart Rate And Weight Measuring Tool For Premature Baby With Microcontroller Base. *International Journal of GEOMATE*, Sept., 2019 Vol.17, Issue 61, pp. 195 -201
- [13] M. G. Ayoub, M. N. Farhan, and M. S. Jarjees, "Streaming in-patient BPM data to the cloud with a real-time monitoring system," *Telkomnika (Telecommunication Comput. Electron. Control.*, vol. 17, no. 6, pp. 3120–3125, 2019.
- [14] S. Indriani, E. Setyoningsih, D. Titisari, and A. J. Wuryanto, "Design Of Asthma Detection Devices Through Heart Rate and Oxygen Saturation", *ijeemi*, vol. 2, no. 3, pp. 143-149, Nov. 2020
- [15] Z. M. Yusof, M. M. Billah, K. Kadir, N. Amanina, N. Hidayah, and H. Nasir, "Design and fabrication of cost-effective heart-rate pulse monitoring sensor system," *Telkomnika (Telecommunication Comput. Electron. Control.*, vol. 17, no. 5, pp. 2497–2504, 2019, doi: 10.12928/TELKOMNIKA.v17i5.9926.
- [16] H. Abdullah, A. Taa, and F. Mohammed, "Remote Patient Health Monitoring System Using Mobile and Wireless Body Area Network in Yemen," *Int. J. Adv. Sci. Eng. Inf. Technol.*, vol. 11, no. 1, pp. 43–50, 2021, doi: 10.18517/ijaseit.11.1.13455.
- [17] A. G. Airij, R. Sudirman, U. U. Sheikh, T. Ide, Y. Nagata, and K. Kamata, "Comparative study on the measurement of human thermal activity," *Int. J. Adv. Sci. Eng. Inf. Technol.*, vol. 9, no. 6, pp. 2160–2165, 2019, doi: 10.18517/ijaseit.9.6.9958.
- [18] I. Zahra, I. D. Wisana, P. Nugraha, and H. J. Hassaballah, "Design a Monitoring Device for Heart-Attack Early Detection Based on Respiration Rate and Body Temperature Parameters", *ijeemi*, vol. 3, no. 3, pp. 114-120, Aug. 2021.
- [19] P. Megantoro, S. A. Aldhama, G. S. Prihandana, and P. Vigneshwaran, "IoT-based weather station with air quality measurement using ESP32 for environmental aerial condition study," *Telkomnika (Telecommunication Comput. Electron. Control.*, vol. 19, no. 4, pp. 1316–1325, 2021, doi: 10.12928/TELKOMNIKA.v19i4.18990.
- [20] J. Wang, "Design intelligent temperature monitoring system based on DSP," *Proc. 2012 4th Int. Conf. Intell. Human-Machine Syst. Cybern. IHMSC 2012*, vol. 2, pp. 234–237, 2012, doi: 10.1109/IHMSC.2012.152.
- [21] A. Rasheedha, K. Srinathi, T. Sivalavanya, R. R. Monisha, and S. Nithin, "Prescriptor using Load Cell," no. 2011, pp. 85–89, 2020.
- [22] S. Jaiteh, S. F. Adillah Suhaimi, T. Ching Seong, A. M. Buhari, L. Lini, and H. Neyaz, "Smart Scale Tracking System Using Calibrated Load Cells," *2019 IEEE Conf. Sustain. Util. Dev. Eng. Technol. CSUDET 2019*, pp. 170–174, 2019, doi: 10.1109/CSUDET47057.2019.9214692.

- [23] R. Basak, S. Roy, and M. Basu, "IOT Based Load Cell Operated Vehicular Overload Detection System to Enhance the Longevity of Flyovers," 2020 4th Int. Conf. Electron. Mater. Eng. Nano-Technology, IEMENTech 2020, pp. 2018–2021, 2020, doi: 10.1109/IEMENTech51367.2020.9270110.
- [24] Zainudin, N. Ahmad Mansor, W. Lee, Khuan Y. Sani, N. H Mohd Mahrim, S. A. Respiratory rate of photoplethysmogram signal from anaesthetic patients. ISCAIE 2015 - 2015 IEEE Symposium on Computer Applications and Industrial Electronics
- [25] Ave, Arrozaq Fauzan, Hamdan Adhitya, S. Rhandy Zakaria, Hasballah. Early detection of cardiovascular disease with photoplethysmogram(PPG) sensor. Proceedings - 5th International Conference on Electrical Engineering and Informatics: Bridging the Knowledge between Academic, Industry, and Community, ICEEI 2015.