

Optimization of Central Air Conditioning Plant by Scheduling the Chiller Ignition for Chiller Electrical Energy Management

Anggara Trisna Nugraha, Lailia Nur Safitri, Naufal Praska Zakariz, Dadang Priyambodo, Adam Meredita Realdo, Fahmi Ivannuri, Alwy Muhammad Ravi, Mayda Zita Aliem Tiwana
Marine Electrical Engineering Shipbuilding Institute of Polytechnic Surabaya, Surabaya
Jl. Teknik Kimia Keputih Sukolilo, Surabaya 60111, Indonesia

Article Info	Abstract
<p>Article History: Received: April 5, 2021 Revision: April 15, 2021 Accepted: May 28, 2021</p> <hr/> <p>Keywords: HVAC Water Chiller Coefficient of Performance (COP) Energy management optimization Efficiency of electrical energy</p>	<p>Currently, the demand for electrical energy in homes, buildings, and industry is increasing, in line with population and economic growth. Of course, because of the massive use of electrical energy, it is necessary to increase efficiency. Large shopping malls in some countries are the biggest consume electricity, especially when it comes to cooling systems. Therefore, it is necessary to save energy in shopping centers. Because there are still few tenants and shopping centers that are relatively quiet, the mall's energy consumption is low, so it requires increasing energy-efficient consumption efficiency by optimizing power management and calculating the chiller performance coefficient (COP). This research aims to increase the chiller performance coefficient (COP) to save energy in shopping centers. The optimization method used is to make changes to the chiller ignition schedule when it's used in malls. Through the analysis from this research, it was found that the COP increased to 0.584, and the value before optimization was 6.181. With increasing COP, the chiller performance will increase. The effect of increasing the chiller's performance could optimize the electrical energy efficiency of the chiller in 138.82 kWh / day.</p>
<p>Corresponding Author: Anggara Trisna Nugraha anggaranugraha@ppns.ac.id, Marine Electrical Engineering Shipbuilding Institute of Polytechnic Surabaya Jl. Teknik Kimia Keputih Sukolilo, Surabaya 60111, Indonesia</p>	<p>This work is an open-access article and licensed under a Creative Commons Attribution-ShareAlike 4.0 International License (CC BY-SA 4.0).</p>



I. INTRODUCTION

Energy is also a vital issue needed in massive quantities [1]. Improved and economic processes with semiconductor diodes to extend energy demand. In keeping with the Energy Conservation Administration [2], the rise in energy demand from 2010 to 2021 shows that the ever-increasing process additionally causes a rise in national energy demand and makes energy use one of the most important contributors to business cost. First, it happened in Some buildings that need a great deal of energy (especially electricity) are multi-story buildings, factories, hospitals, work buildings and search centers [3].

In previous research, which researched the electrical energy management of the chiller had not tested it during holidays. so, there is a lack of test data in data collection for 1 week [4]. A store could be a multi-story building that's within the mall category and needs a great deal of electricity. Nearly 5 per

hundred of the facility is employed to provide an air-conditioning system (AC) [5]. To be able to save a great deal of energy, it needs strategic steps to support the authorization of electrical power the maximum amount as doable whereas still implementing the national energy policy in accordance with the provisions of the Minister of Energy and natural resources [6]. One of these sorts of work is energy expenditure for specific buildings and completely different large buildings. [7] The mall is one amongst the buildings that uses most of its energy to run the air-con system. Therefore, it's necessary to optimize the management of the power of water employed in cooling building.

The mall has three coolers, every with 500TR cooling. three coolers can work at identical times to satisfy the cooling load necessities [8]. Meanwhile, in its current condition, the Mall continues to be comparatively quiet because of its openness, therefore the energy potential ill-usage is low. Therefore, it's

necessary to dissipate a great deal of power through improvement and management of cooling energy, which may lower operative prices because of inefficient power consumption [9]. This research analysis aims to increase the COP and since of that the exciting performance will improve. The optimized excitement power potential is 138.82 kWh / day.

II. MATERIALS AND METHODS

A. Experimental Setup

The advantage of absorption chillers is that they do not require an electric compressor, which means they can provide equipment with significant cooling capacity without causing electrical peaks [10]. When evaluating the suitability of these chillers, a major factor to consider is that they require a large and consistent flow of waste heat to operate properly. Industrial manufacturing facilities are the most obvious candidates, but other locations, such as university campuses, large hospital buildings or large hotels, usually provide ample opportunities for installing absorption coolers [11].

Absorption chillers usually have a condenser, generator, evaporator, damper and heat exchanger. First, refrigerant or water mixed with lithium bromide is stored in the absorption tower [12]. This will be pumped through the heat exchanger and into the generator tank above the coolant. Heat generated from outside or residual steam collected by other systems in the building will enter the coolant. Then the lithium bromide and water are separated by heating. The water gradually turns to steam and rises to the top where the condenser is, while lithium bromide sinks to the bottom [13].

The lithium bromide will flow through the pipe, back into the absorber, and then start from there. Then, the steam at the top of the condenser will pass through the cooling tower. The air pressure of the cooling tower tube is lower than the condenser air pressure. Therefore, when the air pressure drops, the steam becomes water again. Then, cold water enters the evaporator and waits for it to re-mix with the lithium bromide in the absorber.

Absorption chillers in short, absorption chillers cool water through sudden changes in pressure. When the water in the generator gets hot, the air pressure rises. Water gives off heat and turns into steam. Then, the pipe directs the steam to the evaporator at low pressure. Then the steam will cool down and immediately turn to cold water again. When steam absorbs heat and becomes water, the external temperature drops.

The water evaporates and removes all excess heat. Then, when the steam passes through the cooling tower, it is cooled in a low-pressure environment and becomes water again. When water and lithium bromide are mixed in the absorption tower, they can easily pass through the heat exchanger again and carry more excess heat [14].

When an absorption chiller works, it produces cold water and consumes very little electricity, so the pump runs on it. As the heating and cooling cycle progresses, this process continues to remove heat from the building.

B. Refrigeration and Air Conditioning

Cooling and air conditioning are interrelated processes, but each has a different scope. Cooling is the process of lowering the temperature and making the indoor temperature or indoor materials lower than the ambient temperature. In other words, the scope of refrigeration technology lies in the cooling process. AC technology can not only cool the air but also increase the comfort of the user or wearer (comfort air conditioning). According to the definition of air conditioning, the temperature, humidity, flow rate, and cleanliness of indoor air must be adjusted at the same time. Fig. 1 shows the components of the air conditioning system.

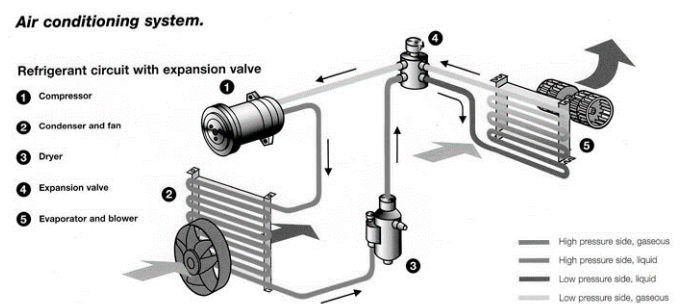

Fig. 1. The Air Conditioning Cycle

In Figure 1, there are 5 main components of the air conditioning system, namely a compressor which compresses the air pressure to flow air, a condenser and fan which functions to condense hot air into water whose hot temperature will be removed by the fan. Then the dryer will dry the air that has been condensed into the water where the temperature has cooled. The expansion valve has a function as an air outlet door, from the expansion valve, the air which is still in the form of water droplets will be dried into steam by the evaporator and blower.

C. Chiller

A chiller is a device for producing cold fluid (secondary refrigerant), used in the cold-water distribution system. The chiller has a large capacity. The refrigeration cycle of the system chiller uses propylene glycol, ethylene glycol, or other secondary refrigerants. On cooler / evaporator, the liquid is cooled by the refrigerant which evaporates at a low temperature. After the liquid is cooled in the cooler, the liquid will enter the coil to cool it download. Thus, the temperature of the liquid will rise and return. to coolant and circulate. In a refrigerant system, the refrigerant vapor is sucked into the compressor and the pressure is increased, Thus, the condensation temperature rises and can be melted in the condenser. In this process, the temperature of the cooling medium of the condenser (water or air) rises. Then, the liquid refrigerant flows into the cooler. evaporator through the refrigerant control device (expansion valve). In expansion devices, refrigerants experience a pressure drop. Thus, the

boiling temperature drops and is lower than the refrigerant temperature secondary [4]. There are many brands of cooling equipment, one of which is Daikin as shown in Fig. 2. The chiller is used to regulate the temperature of the mall building, thus providing comfortable conditions for Mall visitors who shop at the Mall [15].



Fig. 2. Chiller Water Centrifugal Daikin

D. Vapor Compression System

The compressed steam cooling cycle is the most common type of refrigerator in use today. Cooler consists of four main components as shown in Fig. 3, namely compressor, condenser, expansion valve, and evaporator. In this cycle, the low-pressure refrigerant vapor will be compressed by the compressor into high-pressure refrigerant vapor, then high-pressure refrigerant vapor will be condensed into high-pressure refrigerant liquid in the condenser [16]. Then the high-pressure refrigerant liquid passes through the expansion valve to lower the pressure so that the low-pressure refrigerant liquid can evaporate back into the evaporator and become low-pressure refrigerant vapor [17].

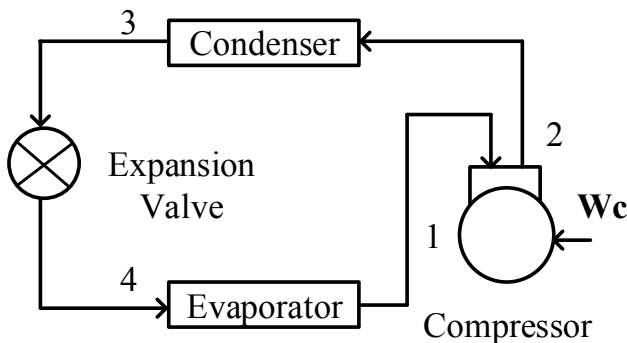

Fig. 3. The Steam Compression System Cycle

E. Basis of Performance Calculation

The basic basis for calculating the performance of the refrigeration system includes the Coefficient of Performance

(COP) and the electrical power consumed by the chiller [18] (1).

F. COPR (Coefficient of Performance)

$$COP = \frac{ER}{Wk} \dots \dots \dots (1)$$

Where, COP indicates the coefficient of performance, ER is refrigeration effect, and Wk shows the electric power consumed by the chiller.

G. Electric Power Consumed

$$Pi = \frac{V.I.Cos\phi.\sqrt{3}}{1000} \dots \dots \dots (2)$$

Where, Pi is the input power of chiller (kW), V is the input voltage (Volt), I is the chiller electric current (Ampere), Cos φ is the chiller power factor while the value of Cos φ used in the chiller is 0.87[19] (2).

H. Chiller Electrical Energy Consumption

The total electrical energy consumed by the chiller during operation can be calculated using the following formula (3):

$$W = P \times t \dots \dots \dots (3)$$

Where, W is the electrical energy (kWh), P is the chiller electric power during operation (kW) and t is the operational time (Hours).

I. Average Electric Energy Consumption per Day

The average daily consumption of electrical energy in the chiller during operating hours can be calculated using the following formula (4):

$$kWh/Day = \frac{\sum P}{t} \dots \dots \dots (4)$$

Where, kWh/Day is the average consumption of electrical energy in one day [20] (kWh), ΣP is the total chiller electrical power during operation (kW) and t is the operational time (Hours)

III. RESULTS

A. Planning for Chiller Electrical Energy Management Optimization

Optimization planning for chiller electrical energy management is carried out by changing the chiller ignition schedule from the existing schedule, which can be seen in Table I.

TABLE I. CHILLER OPERATIONAL SCHEDULE BEFORE OPTIMIZATION

Chiller No.	Time Operational (hour)												
	10	11	12	13	14	15	16	17	18	19	20	21	22
Chiller 1	1	1	1	1	1	1	1	1	1	1	1	1	1
Chiller 2	1	1	1	1	1	1	1	1	1	1	1	1	1

Table I describes the schedule of the chiller before optimization used in the study with the following information:

- Green color: shows the identity of the chiller 1
- Blue color: shows the identity of the chiller 2

• The operational chiller indicator is indicated by numbers 1 (On) and numbers 0 (Off).

From the operational schedule scheme shown in table 1. It can be explained that the operational procedures for the chiller during working days are as follows:

- Chiller 1 operates from 10:00 to 22:00.
- Chiller 2 operates from 10:00 to 22:00.

B. Operational Schedule During Optimization

Operational Schedule When the optimization is divided into 2, namely during active days and during holidays, for the schedule during active days it can be seen in **Table II**.

TABLE II. CHILLER OPTIMIZATION SCHEDULE OPERATIONAL SCHEME DURING WEEKDAYS

Chiller No.	Time Operational (hour)												
	10	11	12	13	14	15	16	17	18	19	20	21	22
Chiller 1	1	1	1	1	1	1	1	1	0	0	0	0	0
Chiller 2	0	0	0	0	1	1	1	1	1	1	1	1	0

Information for schedules planned for weekdays are as follows:

- Green color: shows the identity of the chiller 1
- Blue color: shows the identity of the chiller 2
- Operational indicators are indicated by numbers 1 (On) and numbers 0 (Off).

From the operational schedule scheme shown in table 2. It can be explained that the operational procedures for the chiller during working days are as follows:

- Chiller 1 operates from 10:00 to 17:00.
- Chiller 2 operates from 14:00 to 21:00.

C. Closed Operational Schedule

The operational scheduling scheme for chiller 1 and chiller 2 during holidays (weekends) is carried out alternately and sequentially as shown in **Table III** below:

TABLE III. CHILLER OPTIMIZATION SCHEDULE OPERATIONAL SCHEME DURING HOLIDAYS

Chiller No.	Time Operational (hour)												
	10	11	12	13	14	15	16	17	18	19	20	21	21
Chiller 1	1	1	1	1	1	1	1	1	1	0	0	0	0
Chiller 2	0	0	1	1	1	1	1	1	1	1	1	1	0

Information from table 3 is as follows:

- Green color: shows the identity of the chiller 1
- Blue color: shows the identity of the chiller 2
- Operational indicators are indicated by numbers 1 (On) and numbers 0 (Off).

From the operational schedule scheme shown in table 3 It can be explained that the operational procedures for chiller during holidays are as follows:

- Chiller 1 operates from 10:00 to 18:00.

- Chiller 2 operates from 12:00 to 21:00.

D. Data Collection

Data taken for this study include data on currents, voltages, and parameters for calculating COP. From these data, we will look for the amount of electrical power consumed, electrical energy per kWh, the average consumption of electrical energy per day, and also the results of COP calculations as the main data that answers the problems in this study. From calculations other than COP, it will be obtained how much it costs and how much energy is needed.

E. Current Data

The current data taken is the 3-phase R / S / T chiller electric current on weekdays and holidays. Shown in **Table IV** below:

1. Chiller Electric Current During Weekdays (Weekday)

TABLE IV. DATA FROM FLOW OBSERVATIONS DURING THE WORKING DAY

Time (Hours)	Chiller Electric Current 1 & 2 (A)	
	Before	After
10:00	885,00	445,67
11:00	880,67	433,33
12:00	896,9	432,23
13:00	895,23	430,23
14:00	873,9	882,57
15:00	865,57	888,9
16:00	858,23	884,9
17:00	860,9	848,23
18:00	862,9	418,9
19:00	876,9	421,57
20:00	870,57	408,9
21:00	875,57	348,23
22:00	874,9	-
Average	875.17	526.43

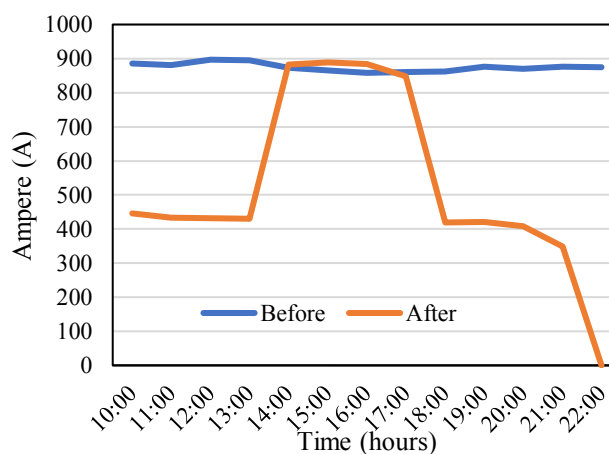

Fig. 4. Chiller current chart during weekdays

As shown in **Fig. 4**, it is explained that the chiller before optimization requires a current in the range of 860.9A to 896.9A when it is operated on weekdays. In the optimized

chiller, the required current is much lower at certain hours and only requires maximum current from 14:00 to 17:00.

2. Electricity During Holidays (Weekends)

TABLE V. DATA FROM FLOW OBSERVATIONS DURING HOLIDAYS

Time (Hours)	Chiller Electric Current 1 & 2 (A)	
	Before	After
10:00	854	459
11:00	859	459
12:00	829	877,33
13:00	879	879
14:00	867,33	867,33
15:00	879	879
16:00	899	899
17:00	899	899
18:00	899	899
19:00	915,67	455,67
20:00	900,67	440,67
21:00	899	439
22:00	904	-
Average	883,36	650,23

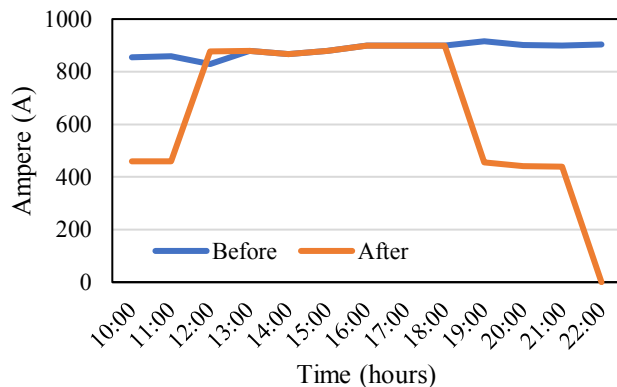

Fig. 5. Chiller current chart during weekends

From Fig. 5 above, it is explained that the chiller before optimization requires a current in the range of 829A to 915.67A when it is operated on holidays. In the optimized chiller, the required current is much lower at certain hours and only requires a maximum current from 12:00 to 18:00 (Table V).

F. The Voltage Data

The voltage data taken is the 3 phase R-S / R-T / S-T voltage. operational time a day at chiller 1 and chiller 2.

TABLE VI. VOLTAGE DATA DURING WEEKDAYS

Time (Hours)	Chiller Electric Current 1 & 2 (A)	
	Before	After
10:00	393	397
11:00	393,5	397
12:00	394	397
13:00	393,83	391
14:00	393	393
15:00	393	392

Time (Hours)	Chiller Electric Current 1 & 2 (A)	
	Before	After
16:00	394	392
17:00	393,33	394
18:00	393	389
19:00	394	394
20:00	394	394
21:00	394	394
22:00	393	-
Average	393,51	363,38

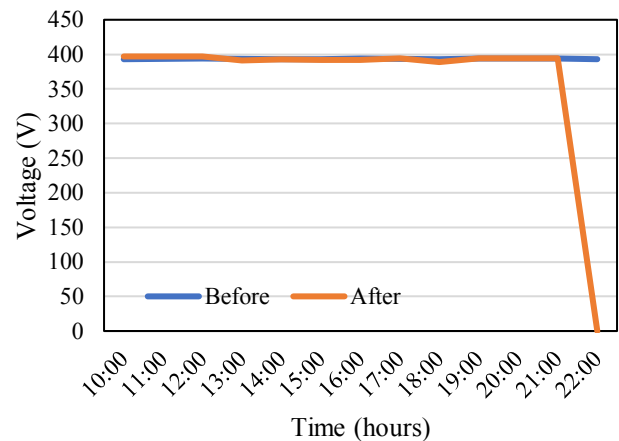

Fig. 6. Chiller voltage graph during weekdays

Fig. 6 and Table VI shows that the chiller before being optimized requires a voltage in the range of 393V to 394V when it is operated on weekdays. For optimized chillers, the required voltage is relatively the same as those that have not been optimized, ranging from 389V to 397V. However, the difference lies at 22:00 where the optimized chiller will shut down at that hour.

G. Electricity Voltage During Holidays (Weekends)

TABLE VII. VOLTAGE DATA DURING HOLIDAYS

Time (Hours)	Chiller Electric Current 1 & 2 (A)	
	Before	After
10:00	395	400
11:00	394	399
12:00	394	399
13:00	394	399
14:00	394	394
15:00	394	394
16:00	394	394
17:00	394	394
18:00	394	394
19:00	394	394
20:00	394	394
21:00	396,5	399
22:00	394	-
Average	394,27	365,69

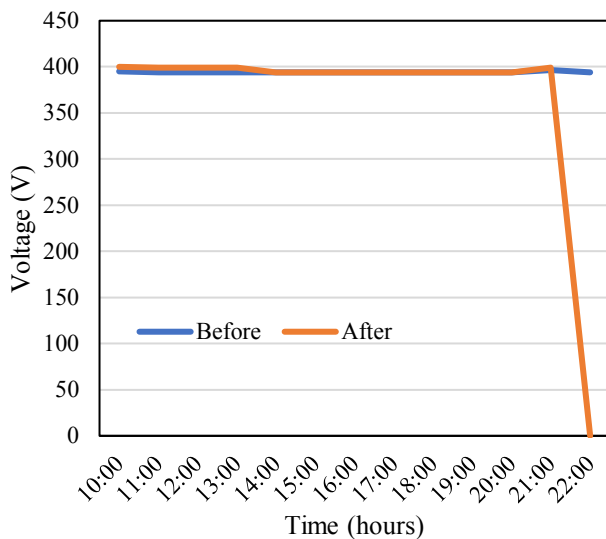

Fig. 7. Graph of chiller voltage during weekends

As shown in Fig. 7, it is explained that the chiller before being optimized requires a voltage in the range of 394V to 396.5V when it is operated on holidays. For optimized chillers, the required voltage is relatively the same as those that have not been optimized, ranging from 394V to 400V. However, the difference lies at 22:00 where the optimized chiller will shut down at that hour.

H. COP Chiller Parameter Data

For COP, the design unit is taken from the name plate of the chiller machine or the specification of the chiller unit located on the chiller machine panel.

1. COP Before Optimization

The following is the current chiller specification before optimization (Table VIII).

TABLE VIII. CHILLER SPECIFICATION DATA

No	Spesification	Data
1	Type chiller	Water Cooled Chiller
2	Cooling capacity	1748 kW
3	Power input	282,5 kW
4	COP	6.175
5	Compressor type	Centrifugal
7	Type of refrigerant	R-134a
8	Supply Voltage	3 Phase 380Volt / 50 Hz

2. COP During Optimization

For COP, after optimization, it is calculated from the cooling capacity data and the power input or power needed to operate the chiller. These data are as follows:

a). COP Data During Weekdays (Weekdays)

The results of data collection for chiller 1 and 2 during the optimization process take place on a working day (Table IX).

TABLE IX. DATA OF COP CHILLER PARAMETERS 1 AND 2 DURING WEEKDAYS

Retrieved Data	Result			
	Chiller 1	COP Chiller 1	Chiller 2	COP Chiller 2
Cooling Capacity	1748 kW	6.478	1748 kW	6.959
Power Consumption	271.40 kW		252.62 kW	
Average of COP in Weekdays	6.718			

b). COP Data During Holidays (Weekend)

The results of data collection for chiller 1 and 2 during the optimization process take place on holidays (Table X).

TABLE X. COP CHILLER 1 AND 2 PARAMETER DATA DURING OPTIMIZATION

Retrieved Data	Result			
	Chiller 1	COP Chiller 1	Chiller 2	COP Chiller 2
Cooling Capacity	1748 kW	6.499	1748 kW	7.125
Power Consumption	270.50 kW		246.72 kW	
Average of COP in Weekends	6.812			

I. Results of Calculation of Chiller Electrical Energy Consumption Before and After Optimization

The results of the calculation of the average electrical energy consumption of the chiller before optimization with the start-up schedule at 10:00 and the blackout schedule at 22:00. While the schedule after optimization is to delay the ignition of chiller number 2 by 4 hours later on weekdays and 2 hours on holidays with the current and voltage values respectively before optimization are: 885A and 394 V and $\cos \varphi = 0.87$. by using equation 2.2, the following results of input power is 524,81kW.

From the results, it can be obtained a comparison of the value of the electric energy consumption of the chiller before and after optimization. It can be concluded that the electric energy consumption of the chiller before optimization is higher than after optimization. Where there is a difference of 138.82 kWh / day where the average power consumption before the optimization is 522.55 kWh / day.

J. COP Average of Chiller During Weekdays and Weekends

From the results of the COP analysis on chiller 1 and chiller 2 during weekdays and weekends, it can be concluded that the COP after optimization increases by 0.584 from the COP before the optimization of 6.181 This is shown in the Fig. 8:

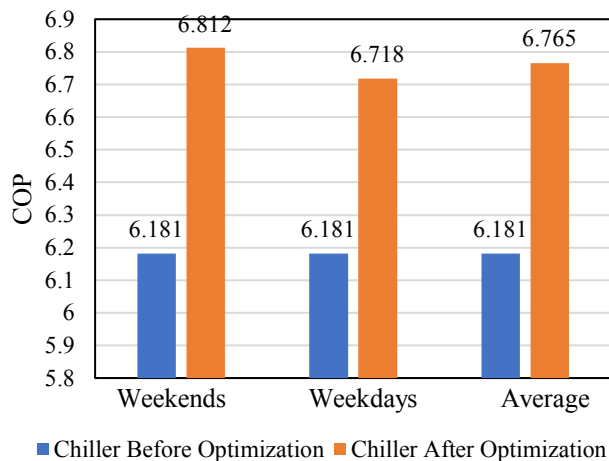

Fig. 8. Comparison Chart of COP Chiller

From the picture above, it is explained that during weekdays, COP Chiller before optimization has increased by 0.631 when compared to the optimized chiller, while during weekends, COP Chiller has increased by 0.537. The average increase in COP Chiller during weekdays and weekends is 0.584.

K. The Resulting Financial Savings

Referring to the Presidential Decree No. 10 of 2011 for electricity rates above 30,000 KVA category provided by PT. PLN (Persero), the cost per kWh is Rp. 971.01, both during WBP and LWBP. Then the saving value that can be generated is:

Financial Rescue in one day is:

$$138.82 \text{ kWh} \times \text{Rp. } 971.01 \times 12 = \text{Rp. } 1.627.547,29$$

Financial Cover in one month is:

$$\text{Rp. } 1.627.547,29 \times 31 = \text{Rp. } 50.143.966,25$$

Financial Rescue in one year is:

$$\text{Rp. } 50.143.966,25 \times 12 = \text{Rp. } 601.727.955, -$$

IV. DISCUSSION

The results of calculating the COP of the chiller by optimization method is to make changes to the chiller ignition schedule when it is used in malls, it can reduce electrical energy consumption in one day as large as 138.82 kWh and operational costs in terms of chiller electrical energy consumption. Referring to the Presidential Decree No. 10 of 2011 for electricity rates above 30,000 KVA category provided by PT. PLN (Persero), the cost per kWh is Rp. 971.01, both during WBP and LWBP, the financial cost can rescue in one year is Rp. 601.727.955, -. Increasing the COP of the chiller will increase the work efficiency of the engine as well. After changing the ignition schedule according to the research method used, it was found that the average COP increase value was 0.584 which indicated an increase in efficiency by 9.45%.

Previous research on chiller power management also looked for the value of the resulting COP, but the drawback in

that study, when compared with this study, is the lack of measurement data and analysis during holidays. Suggestions in this research might be tried with other approaches in order to get a more optimal value.

V. CONCLUSION

From the results of the optimization analysis of chiller electrical energy management carried out at the mall's Central air conditioning plan the COP was increasing by 0.584, while the value before the optimization is 6.181. So that can be concluded if the COP chiller increases the electrical energy consumption can be saved, corresponding to energy management to save electrical energy used and the performance of the machine also will improve. On the other hand, especially for the efficiency of chiller electrical energy obtained after optimization is 138.82 kWh / day, from the initial value before optimization of 522.55 kWh / day, so that it can save costs as well in future use.

REFERENCES

- [1] Saeedi, Mohammadhossein, et al. "Robust optimization based optimal chiller loading under cooling demand uncertainty." *Applied Thermal Engineering* 148 (2019): 1081-1091.
- [2] Bayupancoro in *bayu pancoro, electric, Electric fo Dummies, listrik Posted by Tags: AC Drive, Inverter, Speed Controller, Variable Frequency Drive, Variable Speed Drive, VFD, VSD*
- [3] Mir, Mahdi, et al. "Cooling demand uncertainty modeling in solar photovoltaic based multi-chiller systems." *International Journal of Refrigeration* 103 (2019): 106-114.
- [4] Nugraha, Anggara Trisna, Mayda Zita Aliem Tiwana, and Alwy Muhammad Ravi. "Analisis Optimalisasi Manajemen Daya Chiller Untuk Rencana AC Sentral Industri." *Jurnal Janitra Informatika dan Sistem Informasi* 1.1 (2021): 35-46.
- [5] Zheng, Zhi-xin, and Jun-qing Li. "Optimal chiller loading by improved invasive weed optimization algorithm for reducing energy consumption." *Energy and Buildings* 161 (2018): 80-88. Moch syaik, 2002 *Analisa system pengaturan kecepatan dengan VVVF inverter dan pengereman pada motor penggerak utama KRL produksi PT.Inka madiun*
- [6] Nugraha, Anggara Trisna, and Dadang Priyambodo. "Analysis of Determining Target Accuracy of Rocket Launchers on Xbee-Pro based Wheeled Robots to Realize the Development of Technology on the Military Field." *Journal of Electronics, Electromedical Engineering, and Medical Informatics* 2.3 (2020): 114-118.
- [7] Farmani, Farid, et al. "A conceptual model of a smart energy management system for a residential building equipped with CCHP system." *International Journal of Electrical Power & Energy Systems* 95 (2018): 523-536. Reza Fakhri, Tedjo Sukmadi, Mochammad Facta2, Jurusan Teknik Elektro Fakultas Teknik Universitas Diponegoro Semarang.
- [8] Nugraha, Anggara Trisna, and Dadang Priyambodo. "Design of Pond Water Turbidity Monitoring System in Arduino-based Catfish Cultivation to Support Sustainable Development Goals 2030 No. 9 Industry, Innovation, and Infrastructure." *Journal of Electronics, Electromedical Engineering, and Medical Informatics* 2.3 (2020): 119-124.
- [9] Farmani, Farid, et al. "A conceptual model of a smart energy management system for a residential building equipped with CCHP system." *International Journal of Electrical Power & Energy Systems* 95 (2018): 523-536.
- [10] Nugraha, Anggara Trisna, and Dadang Priyambodo. "Design of a Monitoring System for Hydrogatics based on Arduino Uno R3 to Realize Sustainable Development Goals number 2 Zero Hunger."

Journal of Electronics, Electromedical Engineering, and Medical Informatics 3.1 (2021): 50-56.

- [11] Azuma, Hiroshi, and Sandro Magnani. "Compared analysis of the economic and environmental benefits by using an energy management system in different European countries." *Energy Procedia* 126 (2017): 266-273.
- [12] Capozzoli, Alfonso, Marco Savino Piscitelli, and Silvio Brandi. "Mining typical load profiles in buildings to support energy management in the smart city context." *Energy Procedia* 134 (2017): 865-874.
- [13] Kirschen, Daniel S., Donald W. Novotny, and Thomas A. Lipo. "On-line efficiency optimization of a variable frequency induction motor drive." *IEEE transactions on industry applications* 3 (1985): 610-616.
- [14] Kastha, Debaprasad, and Bimal K. Bose. "Fault mode single-phase operation of a variable frequency induction motor drive and improvement of pulsating torque characteristics." *IEEE Transactions on Industrial Electronics* 41.4 (1994): 426-433.
- [15] Umanand, Prof. L., 2007, Non-Conventional Energy Systems. Bangalore : Indian Institute of Science Bangalore.
- [16] Tong, C.W., 1997, The Design And Testing Of A Wind Turbin For Malaysian Wind Condition, thesis, UTM.
- [17] Hannan, Mahammad A., et al. "A review of internet of energy based building energy management systems: Issues and recommendations." *Ieee Access* 6 (2018): 38997-39014.
- [18] Godina, Radu, et al. "Home HVAC energy management and optimization with model predictive control." 2017 IEEE International Conference on Environment and Electrical Engineering and 2017 IEEE Industrial and Commercial Power Systems Europe (IEEEIC/1&CPS Europe). IEEE, 2017.